

Comparison of ANFIS Based SSSC, STATCOM and UPFC Controllers for Transient Stability Improvement

Ali Shishebori¹, Forough Taki², Saeed Abazari³, Gholamreza Arab Markadeh⁴

1- Department of Electrical Engineering, Islamic Azad University Majlesi Branch, Iran; Member of Young Researchers Club.
Email: a.shishebori@iaumehriz.ac.ir

2- Department of Electrical Engineering, Islamic Azad University Majlesi Branch, Iran; Member of Young Researchers Club.
Email: forough.tsh@gmail.com

3- Assistant Professor, Faculty of Engineering, Shahrekord University, Iran.
Email: Saeedabazari@yahoo.com

4- Assistant Professor, Faculty of Engineering, Shahrekord University, Iran.
Email: Arab-gh@eng.sku.ac.ir

Received: June 2010

Revised: August 2010

Accepted: October 2010

ABSTRACT:

This paper presents the comparative performance of neuro- Fuzzy controlled Voltage Source Converters (VSC) based Flexible AC Transmission System (FACTS) devices, such as Static Synchronous Series Compensator (SSSC), Static Synchronous Compensator (STATCOM), and Unified Power Flow Controller (UPFC) in terms of improvement in transient stability. In neuro-fuzzy control method the simplicity of fuzzy systems and the ability of training in neural networks have been combined. The training data set the parameters of membership functions in fuzzy controller. This Adaptive Network Fuzzy Inference System (ANFIS) can track the given input-output data in order to conform to the desired controller. The maximization of energy function of UPFC is used as an objective function to generate the training data. Proposed method is tested on a single machine infinite bus system to confirm its performance through simulation. The results prove the noticeable influence of ANFIS controlled UPFC on increasing Critical Clearing Time (CCT) of system.

KEYWORDS: Energy function, ANFIS control method, Static Synchronous Series Compensator, Static Synchronous Compensator, transient stability, Unified power flow controller.

1. INTRODUCTION

Transmission networks of modern power systems are becoming increasingly stressed because of growing demand and restrictions on building new lines. One of the consequences of such a stressed system is the threat of losing stability following a disturbance. Flexible ac transmission system (FACTS) devices are found to be every effective in stressing a transmission network for better utilization of its existing facilities without sacrificing the desired stability margin [1]-[3].

There are various forms of FACTS devices, some of which are connected in series with a line and the others are connected in shunt or a combination of series and shunt. The Static Synchronous Series Compensator (SSSC) consists of series connected voltage source converter with coupling transformer in series with the line. SSSC can inject a voltage with controllable magnitude and phase angle at the line frequency [4]. The static synchronous compensators (STATCOM) consist of shunt connected voltage source converter through coupling transformer with the transmission line

[5]. The universal and most effective device is expected to be the Unified Power Flow Controller (UPFC) [6]. This device can independently control more parameters, thus combining the properties of a static compensator (STATCOM), Static Synchronous Series Compensator (SSSC) and phase angle regulator. Fig. 1 shows the schematic diagram of SSSC, STATCOM and the total system, i.e., UPFC.

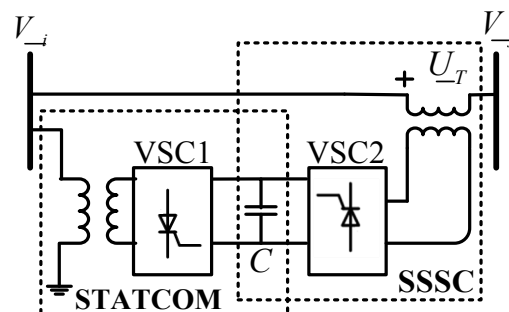

Fig. 1. Basic structure of SSSC, STATCOM and UPFC

Transient stability of electric power systems

considers the problem of loss of synchronism among synchronous generators caused by unwanted large disturbances. Therefore use of a suitable control strategy for these conditions is of particular importance. This paper presents an improvement of the transient stability of power systems using SSSC, STATCOM and UPFC and compares their performance.

In the past, various control techniques with different strategies such as sliding mode control, fuzzy control [7], [8] and Radial Basis Function Neural Network (RBFNN) have been applied for transient stability improvement [9], [10]. Some control methods are based on the second Lyapunov law [11]. A new control strategy for a UPFC for the period of the first-swing angles' propagation is developed in [12]. This control strategy is based on a Lyapunov energy function, which is based on a structure-preserving framework. A structure-preserving energy function (SPEF) has several advantages over the reduced single machine-infinite bus (SMIB) system. From a modeling point of view it allows more realistic representations of the power-system components. Moreover, different kinds of FACTS devices can be considered in a SPEF at different points of the network simultaneously. However, the introduction of new devices, such as FACTS devices, to the power system requires an augmentation of the existing SPEF. In [13] a Lyapunov- based neural network UPFC and in [14] a genetic- H_∞ RBFNN controller is developed for improving power system transient stability. In [15] the RBFN controlled STATCOM, SSSC and UPFC and their performance in transient stability improvement have been compared.

Most of the methods for stability analysis and damping controllers are model based; it means that we should identify system dynamics [16]. Exact modeling of such a system is complicated; but fuzzy logic controllers are usually designed based on system behavior and there is no need to achieve exact model of the system. An essential shortcoming of fuzzy logic controller is that it cannot adjust its parameters in different conditions for the better performance. As opposed to fuzzy logic controllers, learning algorithms are the important ability of neural networks so these two systems can be combined to build neuro-fuzzy systems. Neuro-fuzzy systems make use of comfortable controller designing of fuzzy controllers and the learning ability of neural networks together [17]. A novel methodology of Artificial Neural Network (ANN) based fuzzy control is Adaptive Network Fuzzy Inference System (ANFIS).

In this paper, an ANFIS controller for UPFC, SSSC and STATCOM based on its energy function is proposed in order to improve the transient stability of power system. In part II, the mathematical model is expressed. In section III, the energy function is derived.

In section IV, the control strategy is discussed based on neuro-fuzzy control method and how the transient stability improvement is achieved by using this method. The proposed controller is applied to a SMIB system in section V and simulation results are expressed and compared. Finally in section VI, conclusions of using this method are discussed.

2. MATHEMATICAL MODEL

In a lossless system a UPFC can be represented by a series-connected reactive voltage source with its transformer reactance X_s and a shunt-connected current source. The basic model of a device accommodated in a system between buses i and j and a phasor diagram are presented in Fig. 2 (a-b). A more detailed description can be found in [6] or [18]. Ref [19] suggested that the mathematical model of a STATCOM or a SSSC can be derived from a suitable UPFC model by setting one of its voltage sources to zero. This paper uses this point and extracts the mathematical model for UPFC basically.

The current I_T is in phase with \underline{U}_i and represents the active power exchange between the parallel and series UPFC branches. I_q represents the reactive parallel branch current i.e., for the major part of the operating area, independent of the voltage magnitude U_i . The controllable parameters are U_T , ϕ_T and I_q , whereas I_T depends on the active power injected in the series branch.

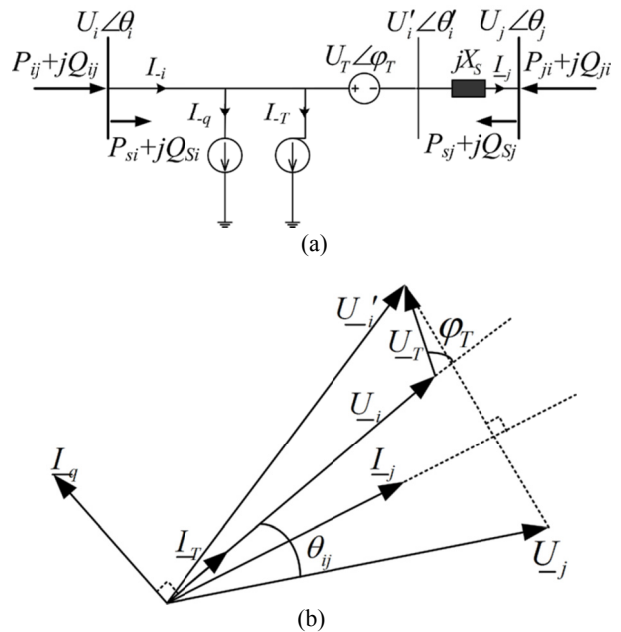

Fig. 2. (a) Basic model of the UPFC and the injected powers; (b) Phasor diagram

U_T represents the magnitude of the injected voltage

\underline{U}_T , φ_T represents the angle of the injected voltage \underline{U}_T , according to the bus voltage \underline{U}_i .

In [20] the injection model for the SSSC is presented. In [12] the active and reactive power injected by UPFC is derived as below:

$$P_{si} = \frac{U_i U_T}{X_S} \sin(\varphi_T) + U_i I_T \quad (1)$$

$$P_{sj} = -\frac{U_j U_T}{X_S} \sin(\theta_{ij} + \varphi_T) \quad (2)$$

$$Q_{si} = \frac{U_i U_T}{X_S} \cos(\varphi_T) + U_i I_q \quad (3)$$

$$Q_{sj} = -\frac{U_j U_T}{X_S} \cos(\theta_{ij} + \varphi_T) \quad (4)$$

According to Fig. 2 $\theta_{ij} = \theta_i - \theta_j$.

UPFC's shunt-connected active power injection with the series branch active power injection can be replaced. This active power is equal to the real part of the scalar product of the series-injected voltage \underline{U}_T and the conjugated value of the current \underline{I}_j . Considering the active power balance constraint as below:

$$U_i I_T = \text{Re}[\underline{U}_T \underline{I}_j^*] \quad (5)$$

After extracting \underline{I}_j and \underline{U}_i' and a few algebraic calculations the active power can be written as:

$$\underline{U}_i \underline{I}_T = \frac{U_j U_T}{X_S} \sin(\theta_{ij} + \varphi_T) - \frac{U_i U_T}{X_S} \sin(\varphi_T) \quad (6)$$

And finally:

$$P_{si} = \frac{U_j U_T}{X_S} \sin(\theta_{ij} + \varphi_T) = -P_{sj} \quad (7)$$

The above equations describe an analytical way to confirm the real power balance of a UPFC ($P_{ij} = -P_{ji}$) [12].

For all the above equations and descriptions if I_q sets to zero, the results will be true for SSSC and if U_T sets to zero, they will be true for STATCOM.

3. ENERGY FUNCTION

It was proved in [6], [20] that if UPFC injects the maximum U_T and I_q , the maximum transient-stability improvement will be achieved. So if we control φ_T in a way that is sectional constant, constructed energy function can be used. The same method used for SSSC and STATCOM. For the construction of energy function for a system with a UPFC the SPEF construction procedure should be followed that can be found in [20]. The same procedure was used in [21] for the case of an SSSC. The generators are presented classically. A first integral of the system equations in

the center-of-angle (COA) frame of reference is used. In this article the loads are considered to be voltage dependent, i.e., modeled as a constant admittance. In [12] the entire energy function of system in terms of rotor angles, rotor velocities and bus voltage magnitudes has been derived. The proposed energy function can be divided into two parts: kinetic energy and potential energy.

In [12] the energy-function construction procedure from [20] is followed and the UPFC's energy function is constructed. With some algebraic calculations assuming that U_T and I_q are set to a maximum and φ_T is sectional constant, a strict Lyapunov function of a UPFC in the form $V_{UPFC} = f(\underline{U}_i, \underline{U}_j)$ is obtained. The potential energy of a UPFC is:

$$V_{UPFC} = \frac{U_T}{X_S} (U_i \cos(\varphi_T) - U_j \cos(\theta_{ij} + \varphi_T)) + U_i I_q \quad (8)$$

This energy function is equal to the sum of the reactive powers Q_{si} and Q_{sj} according to Fig. 2a and represents the total reactive power injected into the power system by the UPFC. Consequently it can describe the energy function of SSSC and STATCOM, too. As a result the total energy function of the system with UPFC, SSSC or STATCOM is:

$$V_{total} = V_{kinetic} + V_{potential} + V_{UPFC(SSSC, STATCOM)} \quad (9)$$

In [12] it is proved that the proposed energy function is Lyapunov function in a certain neighborhood Ω of a post-fault equilibrium point in the state space that relates to the same conditions.

4. CONTROL STRATEGY

4.1. ANFIS Control Method

The neuro-adaptive learning techniques provide a method for the fuzzy modeling procedure to learn information about a data set, in order to compute the membership function parameters that best allow the associated fuzzy inference system to track the given input-output data. The computation of these parameters, or their adjustment, is facilitated by a gradient vector, which provides a measure of how well the fuzzy inference system is modeling the input-output data for a given set of parameters. Once the gradient vector is obtained, any of several optimization routines could be applied in order to adjust the parameters so as to reduce some error measure.

Fig. 3 shows a neuro-fuzzy network called Adaptive Network Fuzzy Inference System (ANFIS) [22]. ANFIS uses either back propagation or a combination of least squares estimation and back propagation called hybrid method for membership function parameter estimation.

Each layer in ANFIS performs a distinct task as follows:

- 1- Computing matching degree of a variable with fuzzy states.

- 2- Computing matching degree of a fuzzy state related to different variables
- 3- Computing normalized matching degree.
- 4- Computing the consequence of a fuzzy rule inference.
- 5- Combination of fuzzy rules consequences in a model.

In this paper, because of using hybrid learning, function of each node should be differentiable, so the Takagi-Sugeno-Kang (TSK) fuzzy model is used.

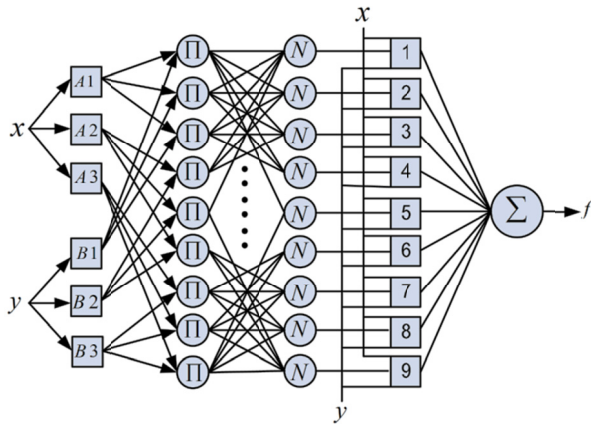

Fig. 3. Structure of ANFIS

4.2. Transient Stability Control

As we mentioned before, the maximum transient stability improvement will be achieved when U_T and I_q set to their maximum value. In the other hand, the more energy UPFC injects, the more transient stability margin will be achieved. Therefore we can use the energy function of UPFC in (8) and control φ_r in a way that maximize the energy function of UPFC i.e., the energy injected by UPFC. Consequently the operation of ANFIS controller is based on the energy function optimization. The output of training data set should be changed in order to make φ_r sectional constant. As Fig. 4 shows U_i and δ have been chosen for the input of controller so as to use energy function operatively, and have more effective control over bus voltage and generator rotor angle. Determination of I_T should satisfy the active power balance limitation; so it cannot be controlled independently.

5. SIMULATION RESULTS

One of the most important tasks in transient stability assessment is the determination of the critical clearing time (CCT).

The proposed technique of improving the transient stability limit by using a UPFC, SSSC and STATCOM is tested on the Single Machine- infinite Bus (SMIB) system of Fig. 4. It is considered that a 3-phase fault

occurs. The critical clearing time for the fault is obtained by a repetition of the simulation with various clearing times.

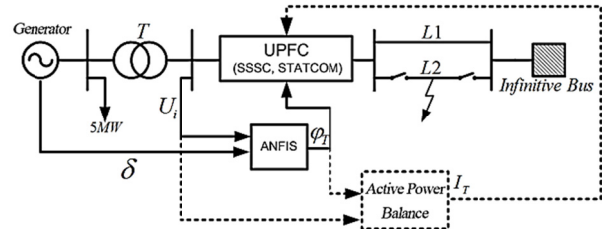

Fig. 4. SMIB test system with the control blocks

In our simulation the system base is 100MVA and 230kV. x_T is the transformer reactance and x_L is the reactance per circuit of the transmission lines. UPFC, SSSC and STATCOM per unit quantities are based on the base MVA and base kV of the system and $X_s = 0.1p.u.$ System data are summarized in appendix.

CCT of the fault is determined for various values of U_T and I_q and the results are summarized in Table I. Results of Table I indicate that, without UPFC the CCT of the fault is only 216ms and it increases to 254ms with UPFC. The UPFC then operate as a STATCOM (by setting $U_T = 0$) and the corresponding CCT is also shown in Table I. Similarly, the CCT of the fault for SSSC operation of the UPFC (when $I_q = 0$) is shown in Table I. The results of Table I confirm that UPFC has the most increase in CCT in comparison with SSSC and STATCOM. It is obvious because the UPFC used both the series and shunt converters whereas the STATCOM or SSSC used only one of the converts of UPFC.

TABLE I. CCT for Various Values of U_T and I_q

Operation	U_T (p.u)	I_q (p.u.)	CCT (ms)	Increase (%)
None	0	0	216	-
UPFC	0.1	0.1	246	13.8
	0.1	0.4	249	15.3
	0.4	0.1	254	17.6
SSSC	0.1	0	244	12.9
STATCOM	0	0.1	243	12.5

Phase plan of system is shown in Fig. 5. The swing curve of the machine, with the UPFC, for a fault clearing time of 235ms is shown in Fig. 6a. For comparison, the swing curve of the machine obtained by operating the UPFC as a STATCOM or SSSC is also shown in Fig. 6.

In the case of UPFC operation, the system has the highest stability margin because of the lowest value of

peak angle during the first swing. The UPFC also provides the maximum damping in subsequent swings.

Fig. 6b shows the swing curve of the machine for the fault clearing time of 245ms that both SSSC and STATCOM are incapable in making the system stable.

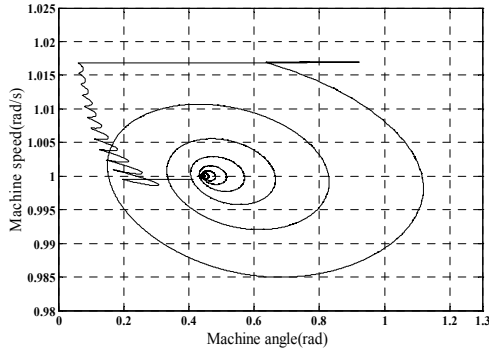

Fig. 5. Phase plan of controlled system

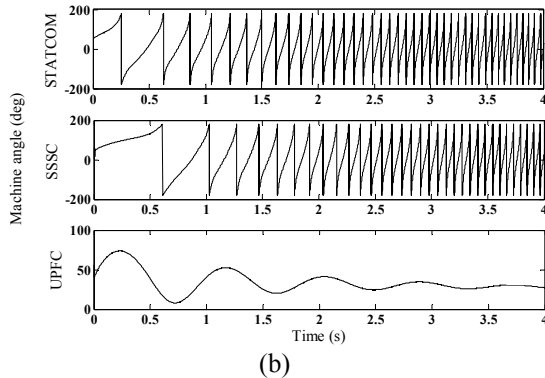
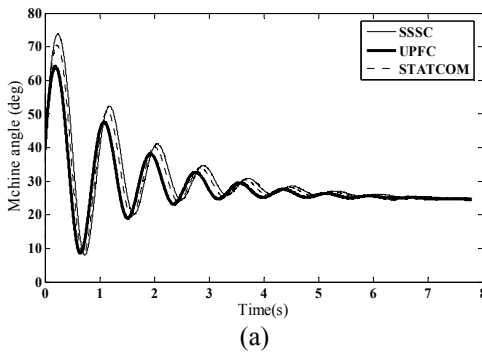

Fig. 6. Swing curve of the machine for various operations of UPFC: (a) Fault clearing time= 235ms; (b) Fault clearing time= 245ms

In Fig. 7 φ_r , i.e., the output of ANFIS controller is shown. It sets the angle of series branch of UPFC based on the training data. Fig. 7 shows that φ_r has its maximum values in first swing of machine angle in order to improve the transient stability the best.

In Fig. 8 the membership functions has been illustrated once before training and then after training. The neural network sets the fuzzy parameters and the

average training error has been obtained 0.01 approximately.

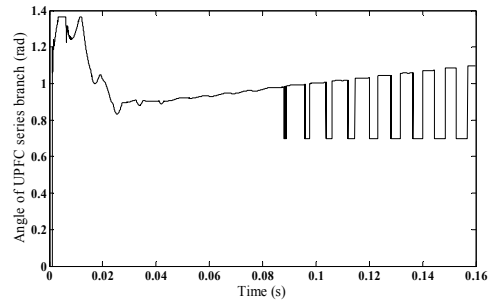

Fig. 7. Series branch angle of UPFC

This method can be extended to multi machine power system using individual machine energy functions [23], [24].

6. CONCLUSION

An Adaptive Network Fuzzy Inference System based UPFC, SSSC and STATCOM for transient stability enhancement has been compared in this paper. The proposed controller combines the robustness and simplicity designing of fuzzy controller and adaptability nature of artificial neural network. The purpose of maximizing the transient stability margin has been achieved by maximizing the injected energy of UPFC by using its energy function. Consequently, the ANFIS controller operation is based on energy function optimization. By keeping the series (shunt) branch inactive, UPFC can operate as a STATCOM (SSSC) and the corresponding behavior is also evaluated and compared. The superiority of the proposed controlled UPFC over a STATCOM or a SSSC in improving transient stability of a single machine infinite bus has been demonstrated. The concepts can be extended to multi machine power system using individual machine energy functions. We are presently investigating the applications of the concepts to multi machine power system.

7. APPENDIX

TABLE 2. Parameters of SMIB System

Parameter	Value	Unit	Parameter	Value	Unit
H	3.120	MJ/MVA	K_E	-	
x_d	1.014	p.u.	T_E	0.243	s
x_q	0.6	p.u.	K_F	0.05	
x'_d	0.314	p.u.	T_F	0.35	s
T'_{do}	6.55	s	K_D	2	
K_A	400		x_T	0.07	p.u.
T_A	0.05	s	x_L	0.65	p.u.

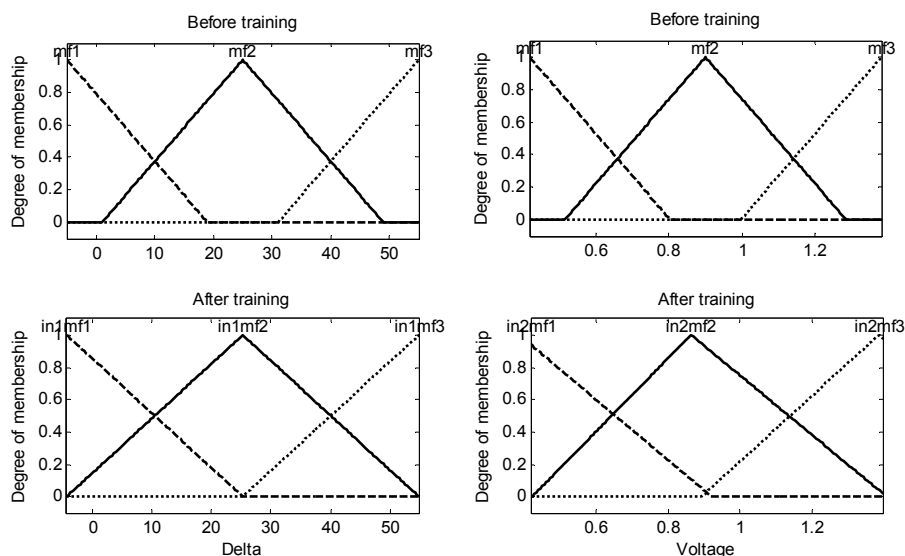

Fig. 8. Membership function of ANFIS inputs before and after training

REFERENCES

- [1] N.G. Hingorani and L. Gyugyi, **Understanding FACTS: Concepts and technology of flexible ac transmission systems**, IEEE Press, NY, (1999)
- [2] Y.H. Song and A.T. Johns, **Flexible AC transmission systems (FACTS)**, IEE Power and Energy Series 30, London, UK, (1999)
- [3] B.Pal, C. Rehtanz, X-P. Zhang, **Flexible AC Transmission Systems: Modeling And Control**, Springer, New-York, (2006)
- [4] K.Sen, "SSSC-Static synchronous series compensator: Theory modeling and application.", *IEEE Trans. Power Delivery*, Vol. 13, No. 1, pp. 241-246, January (1998)
- [5] P.Rao, M.L. Crow, Z.Young, "STATCOM control for power system voltage control application", *IEEE Trans. Power Delivery*, Vol. 15, pp. 1311-1317, (2000)
- [6] R. Mihalic, P. Zunko, D. Povh, "Improvement of transient stability using unified power flow controller", *IEEE Trans. Power Delivery*, Vol. 11, pp. 485-492, Jan. (1996)
- [7] S. Limyingcharoen, U. D. Annakkage, N. C. Pahalawaththa, "Fuzzy logic based unified power flow controllers for transient stability improvement", *IEE Proceedings Generation, Transmission & Distribution*, Vol. 145, No.3, pp. 225-232, May (1998)
- [8] S. M. Sadeghzadeh, M. Ehsan, N. Hadj Said, R. Feuillet, "Improvement of Transient Stability Limit in Power System Lines Using Fuzzy Control of FACTS Devices", *IEEE Transactions on Power Systems*, Vol. 13, No. 3, August (1998)
- [9] N.M. Jothi Swaroopan, P. Somasundaram, "Transient Stability Enhancement with UPFC", *IET-UK International Conference on Information and Communication Technology in Electrical Sciences (ICTES)*, pp. 510-516, Dec. (2007)
- [10] M. H. Haque, "Application of UPFC to Enhance Transient Stability Limit", *Power Engineering Society General Meeting*, pp. 1-6, June (2007)
- [11] M. Januszewski, J. Machowski, J. Bialek, "Application of the direct Lyapunov Method to improve damping of Power swings by Control of UPFC", *IEE Proceedings Generation, Transmission & Distribution*, Vol. 151, No.2, pp. 252-260, March (2004)
- [12] Valentin Azbe, Uros Gabrijel, Dusan Povh, Rafael Mihalic, "The Energy Function of a General Multimachine System With a Unified Power Flow Controller", *IEEE Trans. Power Systems*, Vol. 20, No. 3, pp. 1478-1485, August (2005)
- [13] Chia-Chi Chu, Hung-Chi Tsai, "Application of Lyapunov-Based Adaptive Neural Network Controllers for Transient Stability Enhancement", *Power and Energy Society General Meeting*, pp. 1-6, July (2008)
- [14] S. Mishra, "Neural- Network- Based Adaptive UPFC for Improving Transient Stability Performance of Power System", *IEEE Trans. On Neural Networks*, Vol. 17, No.2, pp. 461-470, March (2006)
- [15] V. K. Chandrakar, A. G. Kothari, "Comparison of RBFN based STATCOM, SSSC and UPFC Controllers for Transient Stability Improvement", *Power Systems Conference and Exposition*, pp. 784-791, Nov (2006)
- [16] P. Kundur, "Power System Stability and Control", McGraw-Hill, Inc. (1994)
- [17] Hariri, O. P. Malic, "Adaptive Network-Based Fuzzy Logic Power System Stabilizer", *IEEE WESCANEX 95 Proceedings*.
- [18] L. Gyugyi, "A Unified Power Flow Control Concept for Flexible AC Transmission Systems", *Proceedings of the fifth International Conference on AC and DC Power Transmission*, pp. 19-26, Sept

- (1991)
- [19] N.Tambey & M.L.Kothari, “**Damping of power system oscillations with unified power flow controller (UPFC)**”, *IEE Proc. Gen. Tran. & Distr.*, Vol. 150, No. 2, pp 129-140, March (2003)
 - [20] Th. Van Cutsem, M. Ribbens-Pavella, “**Structure preserving direct methods for transient stability analysis of power systems**”, *Proceedings of 24th Conference on Decision and Control*, pp 70-77, Dec. (1985)
 - [21] M. Noroozian, L. Angquist and G. Ingestrom, “**Series compensation**”, *Flexible ac transmission systems (FACTS)*, Y. H. Song and A. T. Johns, Ed. London: IEE, cop. 1999, pp 199-242.
 - [22] Jyh-Shing Roger Jang, “**ANFIS: Adaptive-Network-Based Fuzzy Inference System**”, *IEEE Transactions on Systems, Man and Cybernetics*, Vol.. 23, No. 3, pp. 665-685, May-June (1993)
 - [23] PAI, M.A., “**Energy function analysis for power system stability**”, Kluwer Academic, pp. 1418, 1989.
 - [24] N. Michel, A. A. Fouad, V. Vittal, “**power system transient stability using individual machine energy function**”, *IEEE Trans. Circuits and Systems*, Vol. CAS-30, No. 5, May (1983)