

Compensation for Power Quality Improvement in Electric Arc Furnace with Considering Economic Index

Ghazanfar Shahgholian¹, Maryam Golibagh¹

1- Department of Electrical Engineering, Najafabad Branch, Islamic Azad University, Isfahan, Iran.
Email: shahgholian@iaun.ac.ir, Email: maryam_golibagh@yahoo.com

Received: September 2010 Revised: January 2011 Accepted: October 2011

ABSTRACT:

In recent years, on the one hand with increasing application of nonlinear loads in power systems and no sinusoidal currents that extracted from system, and on the other hand increasing loads sensitive to power quality and destructive effects of nonlinear loads on power quality of power systems, compensation these loads has been converted to one of the main issues in power systems. The use of flexible AC transmission system (FACTS) devices is one of the most progressive methods which are used for improving power quality. In this paper, series and parallel compensators of static synchronous compensator (STATCOM) and dynamic voltage restorer (DVR) are introduced and the comparison of these two in compensating of power quality phenomena from electric arc furnace is provided. STATCOM is a shunt active filter and DVR is a series active filter. Method which has been selected for control of every one of these devices is an optimal control way that it minimizes power losses.

KEYWORDS: FACTS, DVR, STATCOM, Arc Furnace.

1. INTRODUCTION

Today issue of power quality has become to one of main and serious cases in electrical power systems which its cause can find in three factors. First industrial equipments sensitive to power quality have increased, second disturbing power quality equipments have found more application, and finally efficiency and gain increase in electricity networks have increasing importance. One of loads which damage power quality is a nonlinear load that is most obvious nonlinear loads of AC electric arc furnace [1-4].

Electric arc furnace can cause problems such as voltage flicker, harmonics, sag, voltage swell, and voltage asymmetries. One of other devices of disturbing power quality is electronic switches. High frequency electronic switches such as switching power supplies can inject harmonics into its supply mains. Some harmonizing devices are fluorescent lamps and speed control drives [5-8].

A model for an ac electric arc furnace considering the highly nonlinear and time varying characteristics of this type of load is presented in [9], which using the nonlinear differential equation that describes the V-I arc characteristic, both voltage fluctuations in the time domain and the arc length are established assuming periodic, stochastic and chaotic variations. A model of EAF and control algorithms for distribution static synchronous compensator for voltage flicker mitigation is

presented in [10], which the EAF was modeled as a current source controlled by a non linear resistance and two control algorithms based on instantaneous reactive power p-q theory and the synchronous reference frame d-q theory were developed. In [11, EAF is assumed as load (the biggest flicker producers) and simulated with chaos theory in MATLAB, then by using various kinds of power line conductors and cables and calculating produced power, the effect of power line conductor's and cable's size on producing voltage flicker is studied.

Starting of large induced motors can cause dropping of instantaneous voltages. The switch of power capacitors can cause voltage pulses. Some problems causing by unsuitable power quality are decreasing of power transmission capacity in power transmission lines, increasing of losses in transmission lines and distribution systems, increasing of current of null point in network, disturbance in protective and measurement equipment operations specially in electricity posts, causing of intension issue, decreasing of long life of electronic devices, false trips of power equipments, false operation of digital control equipments, industrial and home computers, PLCs, and disturbance in speed control drives operation of induced motors. However there are various ways in order to encounter with these problems. First we will resist all equipments sensitive to power quality phenomena against these phenomena by one standardization system.

Since these equipments have many variations then in practice doing this work is not possible. Second way is cleanness of network from these phenomena.

Electricity industry researchers have suggested various methods to compensate of power quality phenomena that most obvious these ways is the using of passive filters and active filters. Passive filters classify to down path, up path, middle path, and adjusted filters groups with respect to frequency limit which they pass. Because of many problems of passive filters including no flexibility against multiplicity of disturbing frequencies, active filters issue was brought up. This category of filters based on structure divide to two categories of single phase and three phases, and based on connection manner to network divide to shunt, series, and hybrid groups [12].

The analysis of topologies and control strategies based on parallel and series active filters for voltage flicker compensation is described in [13], which the control strategies of the active filters have been analyzed in the frequency domain as well.

One of parameters that limit active filters application is high cost of these filters especially in high ranges of power. Therefore, using of loading lower than filter and more advanced control ways, we can decrease its cost and generalize their use. In addition, using of issue of compensation of power quality phenomena and reactive power can improve power transmission capacity and also can increase efficiency of network. Among latest series active filters technology can point to static synchronous series compensator (SSSC) and DVR [14]. These filters use to compensate of voltage problems. In addition, SSSC performs compensation of voltage problems only in base frequency. Also among parallel active filters can point to Static Var Control (SVC) and STATCOM. This category needs to complicated control algorithms and also simultaneous use of passive filters in order to compensate power quality phenomena because this group removes some problems of power quality related to current and also it has no ability of solving voltage problems arising from nonlinear loads.

Considering to mentioned explanations, purpose in this paper is selecting suitable compensator for electric arc furnace. In other words, series compensator is used to obtain which compensator and parallel compensator is used to obtain which compensator. Difference of this paper is new modeling of arch kiln and compensation of its power quality phenomena with series and parallel compensator.

2. ELECTRICAL ARC FURNACE MODEL

Three phase electric arc furnace are most common tools for melting steel in high capacities. Power supply of kilns includes one dropping transformer which its

output joints to three graphite electrode through flexible cables. When three voltage about 400-1000 volt reached to top of the electrodes, a hydraulic system composes of one hydraulic unit as well as serving related values and three jack for three electrodes conducts manual or automatically electrodes simultaneously and with equal speed toward down. When every three electrodes reached to special level which met to steel inside kiln therefore the direction of current is closed through steel and every three electrodes begin to arch. Since direction of closing current between three electrodes is never symmetrically and or in other words resistance and inductance of direction is not equal between every two electrodes especially the beginning of melting (because of charging scrap inside electric arc furnace) then it creates imbalance of load and voltage current. We will gradually have Swell, Sag, and voltage flicker phenomena and electric arc furnace starts harmonization on power system. In here, means has been thought for balancing three phase current. Electrode regulation helps to electric arc furnace as has been showed in figure; one PLC is responsible for this regulation. Information entered to PLC is three phase instantaneous voltages currents and output of this advanced regulation is three analogue voltages in range of ± 10 volt which every voltage supplies hydraulic values of jack jointed to electrode. In fact, taking up and down every electrode independently and automatically causes three phase voltages and currents regulate to well limit but yet power quality problems damage supply network. PLC has this ability to receive many numbers of other parameters such as curve necessary to increase current and information about type of electrodes and range of voltage changes by key pad OP25 and to make decision according them. During past decade, electrode regulation was based on current control while today new systems have replaced old electrode regulation. Recently, Arcos Company has replaced current control way with impedance control way. In this way, addition to more dynamic response speed, there is better control on current and voltage of electric arc furnace.

Two recognized and proved models which have most adaptation with reality are Cassi and Myre models. Cassi model has provided to electric arc furnace with high current and Myre model has provided to arches with low current. Myre model considers steady the arch column with temperature and conduction and also it considers variable the location of creating arch that saved energy and wasted energy is proportional to this change of location. Whereas Mayre considers steady the location of creating the arch or length of arch column and also it considers variable the temperature and conduction in the length of arch

column, Cassi equation is in form of (1) [15].

$$G = \frac{v * i}{E_0^2} - \theta * \frac{dG}{dt} \tag{1}$$

where E_0 is instantaneous voltage of stable mode of arch, and θ is time constant of arch which is equivalent to saved energy on the basis of per unit divided to wasted energy on the basis of per unit? Instantaneous voltage of stable mode is time which arch has reached to steady mode. G is conduction of system, v and i are instantaneous voltage and current respectively. Mayre's equations are in form of relation (2).

$$G = \frac{i^2}{P_0} - \theta * \frac{dG}{dt} \tag{2}$$

One way for combining (1) and (2) in form of a single steady model is definition of one property called $S(i)$ which this property is current strength function. According to this assumption, G defines in form of equation (3).

$$G = (1 - S(i)) * G_C + S(i) * G_M \tag{3}$$

where G_C and G_M are conductance provided in (1) and (2). One suitable form is equation (4) to $S(i)$ which in this definition, I_0 is transmission current of stable mode and i is the value of instantaneous current.

$$S(i) = \exp\left(-\frac{i^2}{I_0^2}\right) \tag{4}$$

When i is small, the value of $S(i)$ goes toward 1; therefore we have Myre model in equation (3) while in high currents the value of $S(i)$ goes toward zero and we have Cassi model. In these formula must be existed one minimal value to conduct even when current of electrodes is zero and conductance between two electrodes is very small. This conductance that has been showed by G_{min} depends on distance between two electrodes, type and temperature of electrodes. Complete model expresses via relations (5) and (6):

$$G = G_{min} + (1 - \exp\left(-\frac{i^2}{I_0^2}\right)) * \frac{v * i}{E_0^2} + (\exp\left(-\frac{i^2}{I_0^2}\right)) * \frac{i^2}{P_0} - \theta * \frac{dG}{dt} \tag{5}$$

$$i = G * V \tag{6}$$

In general form, θ must be function of arch current that relation (7) expresses such function.

$$\theta = \theta_0 + \theta_1 * \exp(-\alpha|i|) \tag{7}$$

3. DYNAMIC VOLTAGE RESTORER

As mentioned in introduction, DVR of a series compensator as shown in Fig. 1. This structure, which composed of a 6 pulse voltage source converter and through a series transformer couples with transmission line, can remove problems of system voltage by injecting a voltage of compensation in an optimal

angle.

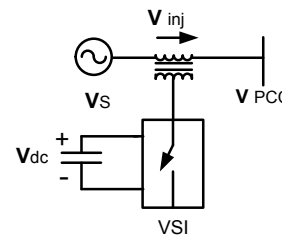

Fig. 1. Structure and type of connection to DVR network

Responsibility of series compensator is the injection of a compensation voltage into system in an optimal angle in order to remove problems such as SAG, SWELL, FLICKER, and UNBALANCE voltage, and in other words active power regulation. Responsibility of parallel compensator is the injection of compensation current, in form of pre-phase with common point voltage, in order to compensate current harmonics and reactive power of system.

3.1. DVR Control Algorithm

Fig. 2 shows simple algorithm to DVR control. This control structure performs two works:

1. It compensates zero and negative sequences of voltages in the system.
2. It decreases loading from compensator.

Whenever we have a set of balanced voltages, zero and negative sequences of voltage have zero value for this set. One part of proposed algorithm always keeps components of zero and negative sequences of source voltage in zero. The manner of work will express.

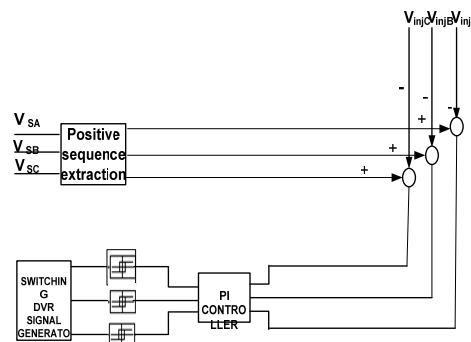

Fig. 2. DVR control algorithm in simple way

3.2. Extraction of reference voltage for DVR

Reference voltage for DVR constructs from components of base voltage sequence which this work performs with taking mean on half cycle. Components of base sequence obtain average of sum of several means of half cycle. Advantage of this way is that average values of a signal are available continuously

and every disturbance in variables of system appears in the mean of subsequent half cycle. According to relation (8), using of instantaneous symmetrical components method, we can obtain a, b, c phases from source voltage of positive, negative, and zero sequences [16].

$$\begin{bmatrix} V_{Saz} \\ V_{Sap} \\ V_{San} \end{bmatrix} = \frac{1}{\sqrt{3}} \begin{bmatrix} 1 & 1 & 1 \\ 1 & a & a^2 \\ 1 & a^2 & a \end{bmatrix} \begin{bmatrix} V_{Sa} \\ V_{Sb} \\ V_{Sc} \end{bmatrix} \quad (8)$$

In relation (8), a=e and V is zero sequence vector and V, V are positive and negative sequence vectors respectively that two recent vectors are each other mixed coupled. If phasors of positive, negative, and zero sequences show V_a, V_b, V_c then these phasors obtain relation (9).

$$V_{azpn} = \frac{\sqrt{2}}{T} \int V_{azpn} e^{-j(\omega t - 90^\circ)} dt \quad (9)$$

where in above relation, V of time of T selects in form of half cycle. Therefore base positive sequence voltages, V_r , obtain to use of taking mean way on half cycle. Relation (10) shows errors of source voltage which this error consists of negative and zero sequences. This error signal, DVR is supplied through one SPWM until DVR can be injected into an opposite phase voltage in order to remove negative and zero sequences from supply voltage.

$$V_{err} = V_S - V_P \quad (10)$$

Computing of DVR load during balancing of lack voltage carries out based on linear load in base frequency. From phasor diagram of Fig. 3 with per unit of considering values, when have lack of voltage, after creating this lack, voltage obtains relation (10) which X is lack value of voltage according to per unit. Now in order to keep steady of active power under condition of lack of voltage then relation (12) and (13) must establish.

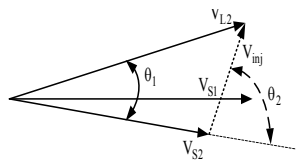

Fig. 3. Vector diagram of compensated and uncompensated voltages

$$V_{S2} = (1 - X) V_{S1} \quad (11)$$

$$V_{S1} I_{S1} = V_{S2} I_{S2} \quad (12)$$

$$I_{S2} = \frac{I_1 \cos \varphi}{(1 - X)} \quad (13)$$

According to relation (14), range of loading from DVR is function that it depends on φ and x parameters which these two parameters are independent.

$$V_{Arating} = V_{inj} I_{S2} = \frac{\cos \varphi}{(1 - x)} |V| \quad (14)$$

3.3. Control Strategy

In order to facilitate this study, optimization section of MATLAB software has been use to determine optimal θ_1 . Angle of θ_2 and $|V|$ are used. Optimal θ_2 angle is obtained. In next step in order to obtain $|V|$ signal, we deduct value of positive sequence of power supply from size of voltage of power supply. Now two signals of θ_2 and $|V|$ determine reference voltage to inject into system. Similar to algorithm of previous sample, size and phase quantities convert to adjusted positive sequence voltages. As it is clear in algorithm, first negative and zero sequence deduct from these voltages. Also value of real voltage of two top of compensator in every phase deducts from it in next step. Then it passes one limited controller PI in order to increase dynamic operation of system ($K=1$ and $K=0.001$). Stability of compensator can be ensured by correct determination of PI controller parameters.

4. STATIC SYNCHRONOUS COMPENSATOR

STATCOM is a synchronous static generator which similar to variable static compensator with parallel connection, controls ac voltage of system. Fig. 4 represents main diagram of STATCOM. Essentially STATCOM is a synchronous voltage generator (SVG) that it generates a three phase voltage from synchronous dc source to line voltage. The amplitude of STSTCOM voltage is able to adjust reactive power changes between STATCOM and transmission system. According to Fig. 4, V_s is phasing to V_t phase. However there is a small value of switch in converter and coupled transmission losses. When V_s and V_t are phasing, STATCOM current is to bus voltage and STATCOM voltage or v_s and therefore reactive current is I_q . Amplitude of I_q current and reactive power changes is between transmission system per unit and STATCOM. A synchronous static generator or variable static compensator of parallel connection controls output current or capacitor toward ac voltage [17, 18].

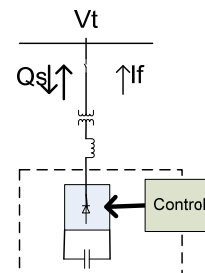

Fig. 4. Simple STATCOM structure

4.1. Basic STATCOM Control

Three level converters and PWM can adjust two level converters that are able to control of voltage amplitude and angle of output AC voltage via signals ratios. Therefore only way of output ac voltage amplitude control through adjusting input dc voltage converter of output ac voltage increase is increasing dc voltage reversely. Control procedure of dc capacitor voltage is obtained by small movement of $\Delta\alpha$ phase between STATCOM voltage and voltage V_s of V_t transmission system. Also these phase changes need to compensate switch losses through transmission system. In practice, V_s is always before V_t via small values of (0.1-2) and a small real power of transmission system flows dc capacitor in order to compensate converters switch and transmission losses. In addition, temporary movement of positive and negative phase needs to charge or de-charge of capacitor such an additional section to control system.

4.2. Application and Control Structure of STATCOM

STATCOM responsibilities in distribution and transmission system are:

1. Power factor correction close to unit with injecting reactive current which this current usually has phase displacement with PCC voltage of 90° line.
2. Support of voltage which this compensator has ability of fast compensation of voltage with injecting reactive current in ends of lines.
3. Compensation of unbalancing load
4. Compensation of voltage flicker
5. Remove current harmonics and eliminate DC OFFSET in loads.

STATCOM makes balance and sinus source currents to inject a current.

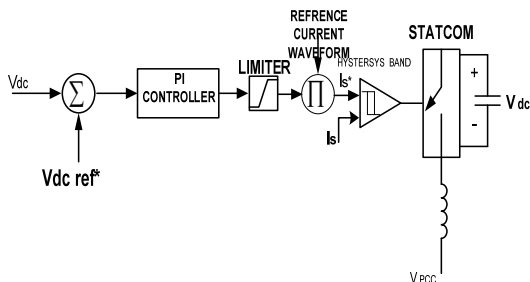

Fig. 5. STATCOM control algorithm

Fig. 5 shows STATCOM control algorithm. As it is clear in this algorithm, in addition to compensate power quality phenomena, one of responsibilities of this compensator is keeping steady of DC voltage of capacitor link. This algorithm uses two reference values to determine fire angles. These two values include real DC voltage difference and reference

voltage, and reference currents difference and real currents. Among algorithm can compensate reactive power of system rely on equations (15) and (16).

5. SIMULATION RESULTS

We have performed simulation to mentioned electric arc furnace model in section 1 of Matlab/Simulink software with mentioned control method for STATCOM and DVR. Fig. 6 show uncompensated current and voltage for electric arc furnace. Fig. 7 shows extracted reactive power quantity from source to uncompensated electric arc furnace.

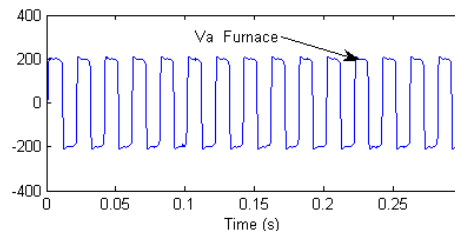

Fig. 6. A phase voltage waveform graph of electric arc furnace before compensating

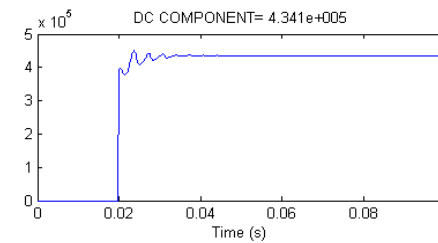

Fig. 7. Consumed average reactive power by uncompensated electric arc furnace

Figs. 8 and 9 show frequency spectrum for these waveforms. Numbers of written on frequency spectra show the necessity of compensating to electric arc furnace. Figs. 10, 11, and 12 show voltage, current and stretched reactive power waveforms from source after compensating via DVR respectively. Also Figs. 13, 14 and 15 show adjusted voltage, current, reactive power and DC voltage waveforms via STATCOM. In Fig. 16, in moment of 0.1 second, compensator has existed from circuit so that capability of STATCOM has been showed in compensating of voltage.

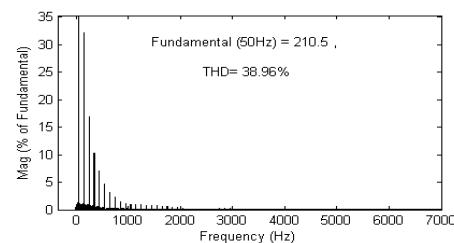

Fig. 8. Frequency spectrum of a phase voltage of source before compensating

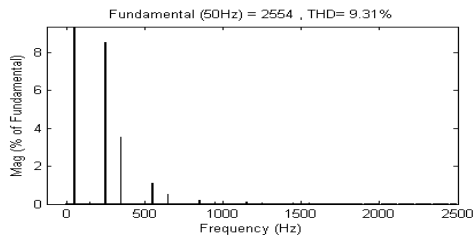

Fig. 9. Frequency spectrum of source current before compensating

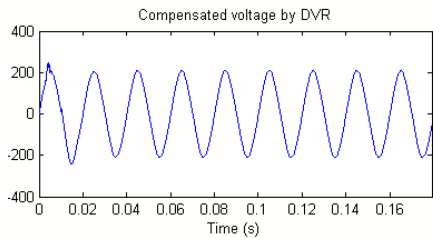

Fig. 10. A phase voltage waveform of power supply after compensating by DVR

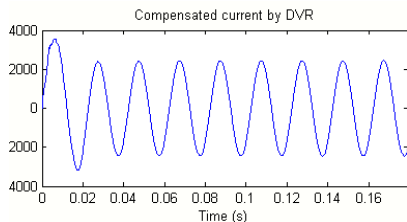

Fig. 11. A phase current waveform after compensating by DVR

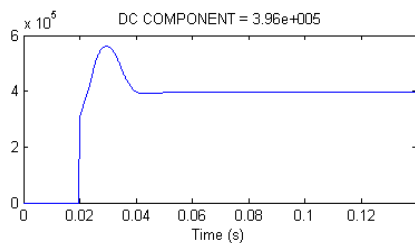

Fig. 12. Average of consumed reactive power by electric arc furnace after compensating via DVR

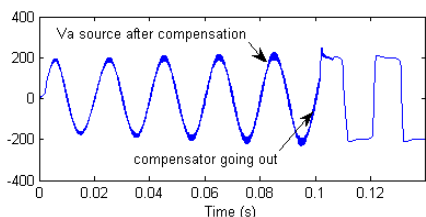

Fig. 13. A phase voltage of compensated and uncompensated source by STATCOM

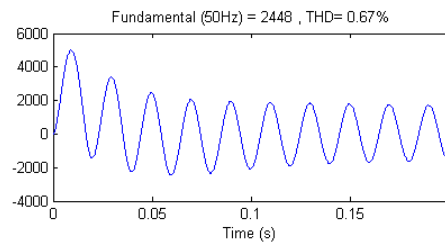

Fig. 14. A phase bus current of compensated electric arc furnace source STATCOM

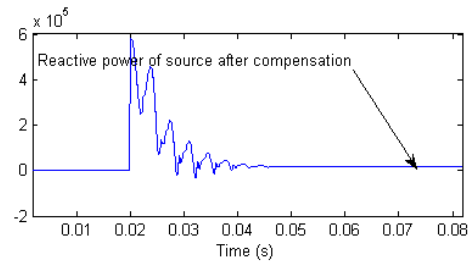

Fig. 15. Average of stretched reactive power of power supply after compensating via STATCOM

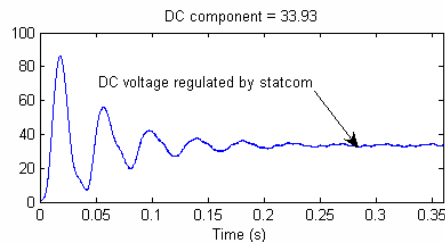

Fig. 16. Adjusted DC link voltage by STATCOM

Table 1 shows a comparison between simulation results. Considering table, in parallel compensation, frequency spectrum of voltage has reached from %38.98 to %3.49 and frequency spectrum of current has reached from %9.31 to %0.51 which has significant role in compensating current harmonic. In series compensation mode, the value of frequency spectrum of voltage has reached to %2.24 and the value of frequency spectrum of current has reached to %1.76. These numbers show the index of compensators in improving harmonics of kiln. According to Table II, with respect to any KVA for STATCOM, DVR estimates about \$300. First, by transforming it to common mode from per unit form by considering value of S equal to 10000 calculates price value of any one of equipments.

With respect to Table I and II, in comparison between STATCOM and DVR, price value in return to loading from compensator is following form:

DVR:

$$0.132 * 10^5 = 13200$$

$$132 * 10^2 * 300\$ = 39.6 * 10^5 \$$$

STATCOM:

$$0.119 \times 10^5 = 11900$$

$$119 \times 10^2 \times 300\$ = 35.7 \times 10^5 \$$$

Table 1. Comparison between active filters in compensating power quality phenomena and loading

Type of compensator	Reactive power pulled from source	THD of source voltage	THD of source current	Loading from compensator (per unit)
Arctlo kiln without filter	0.74%	34.11%	10.96%	0
Compensation of series active filter	0.699%	2.42%	1.76%	0.132%
Compensation of parallel active filter	0	3.49%	0.51%	0.119%
Compensation of combination of passive and parallel active filter	0	1.52%	1.10%	0.117%
Compensation of combination of passive and series active filter	0.19%	2.87%	0.46%	0.98%

Table 2. Pricing of filters

	Cost For KVA	Maintains and stand by
UPS	\$400	10%
Fly wheel	\$250	5%
DVR	\$300	5%
STATCOM	\$300	5%
UPFC	\$200	1%
PASSIVE FILTRE	\$15	1%

Which saving amount is about 3.9×10^5 in obtaining power from parallel active filter. In next step, we represent to calculate combined compensators. In first mode, we calculate combined compensator of parallel active filter and passive filter in following form:

DVR + Passive Filter:
 $(0.132 - 0.117) \times 10^5 = 1500$
 $1500 \times \$300 = 4.5 \times 10^5 \$$

STATCOM + Passive Filter:
 $(0.119 - 0.98) \times 10^5 = 2100$
 $2100 \times \$300 = 6.3 \times 10^5 \$$

Which saving amount is about 1.8×10^5 in obtaining power from parallel active filter. Noticeable fact is that we should deduct investment cost from this number to passive filter. By Table (1-4), it can calculate investment cost to passive filter. Parallel active filter and passive filter of combined mode calculate in following form:

$$(119 - 98) \times 10^2 \times \$15 = 31500\$$$

$$(63 \times 10^5) - (315 \times 10^2) = 6268500\$$$

And for series active filter mode with passive filter

calculate in following form:
 $(132 - 117) \times 10^2 \times \$15 = 22500\$$
 $(45 \times 10^5) - (225 \times 10^2) = 4477500\$$

6. CONCLUSION

As investment cost is equal to \$31500 for passive filter to parallel composition mode and is equal to \$22500 for series composition mode, these are small numbers that its calculations noted above steps. With respect to performed calculations, we can abandon to this small number.

In this paper, simulation results were performed to arc to kiln model and also to compensate it with series, parallel active compensators and combining of active and passive compensators. As it observed in simulation results, series compensator can well remove source voltage problems while this compensator's success is very low to compensate reactive power. Also this compensator performs to acceptably compensate current. Parallel compensator that operates based on injecting current to network, can perform acceptable compensating current. But compensating voltage problems is not as amount as compensating current problems in this compensator. Here we have two issues. One is lack of voltage and other is gap and flicker phenomena. Since power of this compensator limits to compensate other power quality phenomena related to voltage, then this matter is completely obvious in simulation results of parallel compensator for voltage. One of the advantages this compensator is its extra ability to compensate reactive power.

REFERENCES

- [1] A. Esfandiari, M. Parniani, H. Mokhtari, "Mitigation of electric arc furnace disturbances using the unified power quality conditioner", *IEEE/IECON*, Vol.2, pp.1469-1474, Nov. 2004.
- [2] Y.J. Hsu, K.H. Chen, P.Y. Huang, C.N. Lu, "Electric arc furnace voltage flicker analysis and prediction", *IEEE Trans. on Inst. and Meas.*, No.99, pp.1-9, April 2011.
- [3] P. Shafaghi, G. Shahgholian, A. Etesami, S. Khalili, "The Effect of Corrosion of Electrodes in the Electric Arc Furnaces Model", *IEEE/ICCEE*, pp.35-39, Dece. 2009.
- [4] J. Ruiz, J. Ubierna, A. Aramendi, E. Leturiondo, L.A. Amantegui, "PC based multichannel system for real time harmonics and flicker measuring", *IEEE/MELCON*, pp.968-971, Apr. 1994.
- [5] L. Xiuhe, Y. Guang, S. Wei, "Harmonic current detection of electric arc furnace system based on the method of eliminating zero-sequence component", *IEEE/ICICTA*, Vol.1, pp.431-433, March 2011.
- [6] J.L. Guan, M.T. Yang, J.C. Gu, H.H. Chang, C.L. Huang, "The effect of harmonic power fluctuation for estimating flicker", *Wor. Acad. of Sci., Eng. and Tec.*, Vol.28, pp.200-205, 2007.

- [7] Y. Djeghader, H. Labar, K. Bounaya, “**Analysis of harmonics generated by different structures of a DC EAF**”, *Int. Rev. of Ele. Eng. (IREE)*, Vol.1, No.1, Oct. 2008.
- [8] G.W. Chang, C.I. Chen, Y.J. Liu, “**A neural-network-based method of modeling electric arc furnace load for power engineering study**”, *IEEE Trans. on Pow. Sys.*, Vol.25, No.1, pp.138-146, Feb. 2010.
- [9] A.A. Gomez, J.J.M. Durango, A.E. Mejia, “**Electric arc furnace modeling for power quality analysis**”, *IEEE/ANDESCON*, pp.1-6, Sep. 2010.
- [10] K. Anuradha, B.P. Muni, A.D.R. Kumar, “**Modeling of electric arc furnace and control algorithms for voltage flicker mitigation using DSTATCOM**”, *IEEE/IPEMC*, pp.1123-1129, Wuhan, May 2009.
- [11] A. Roghani Araghi, S. H. Hosseinian, A. Doroudi, I. Salabeigi, “**A novel approach to cable’s and line’s sizing in distribution system based on flicker effect**”, *Int. Rev. of Ele. Eng. (IREE)*, Vol.2, No.6, pp., Dec. 2009.
- [12] H. Fujita, H. Akagi, “**A practical approach to harmonic compensation in power systems-series connection of passive and active filters**”, *IEEE Trans. on Ind. Appl.*, Vol.27, No.6, Nov./Des. 1991.
- [13] J. Dolezal, A.G. Castillo, J. Tlustý, V. Valouch, “**Topologies and control of active filters for flicker compensation**”, *IEEE/ISIE*, Vol.1, pp.90-95, Aug. 2000.
- [14] K. Sadigh, A. Hosseini, S.H. Farasat, M. Mokhtarpour, “**Voltage flicker mitigation with dynamic voltage restorer**”, *IEEE/PEDSTC*, pp.388-392, Feb. 2010.
- [15] M. Routimo, A. Makinen, M. Salo, R. Seesvuori, J. Kiviranta, H. Tuusa, “**Flicker mitigation with a hybrid compensator**”, *IEEE Trans. on Ind. Appl.*, Vol.44, No.4, pp.1227-1238, July/Aug. 2008.
- [16] M. Gonzalez, V. Cardenas, N. Visairo, “**Voltage regulation with a dynamic voltage restorer using reactive power for low DC energy storage utilization**”, *Int. Rev. of Ele. Eng. (IREE)*, Vol.4, No.1, pp.75-85, Jan. 2009.
- [17] G. Shahgholian, “**Development of state space model and control of the STATCOM for improvement of damping in a single-machine infinite-bus**”, *Int. Rev. of Ele. Eng.(IREE)*, Vol.4, No.6, pp.1367-1375, Nov./Dec. 2009.
- [18] Y.F. Wang, J.G.Jiang, L.S.Ge, X.J.Yang, “**Mitigation of electric arc furnace voltage flicker using static synchronous compensator**”, *IEEE/IPEMC*, 2006.