

Design of Math Function Based Controller for Smooth Switching of Hybrid Energy Storage System

Raghavaiah Katuri^{1*}, G. Srinivasa Rao²

1- Department of Electrical Engineering, Vignan's Foundation for Science Technology and Research, and Vadlamudi, India.

Email: rk_eeep@vignanuniversity.org.org (Corresponding author)

2- Department of Electrical Engineering, Vignan's Foundation for Science Technology and Research, and Vadlamudi, India.

Email: raghava.katuri@gmail.com

Received: December 2017

Revised: January 2018

Accepted: February 2018

ABSTRACT:

Hybrid Energy Storage System (HESS) has been implemented for better energy efficiency to Hybrid/Electric Vehicles (HEV/EV), in that the main source is Battery and UltraCapacitor (UC) is the auxiliary source. The battery is connected to DC Bus through Boost Converter and UltraCapacitor has been connected through Buck-Boost Converter. Battery and UltraCapacitor voltages levels are maintained less than the DC bus voltage. The main aim of this paper is to design an intelligent controller for a smooth transition between the sources in the Hybrid Energy Storage System. Math Function Based (MFB) Controller has been modelled and implemented to an electric motor for Electric/Hybrid Electric Vehicle Application. The MFB controller has to work based on the Speed of the motor and this controller makes the closed loop operation of the overall system with smooth operation between the energy sources. Proportional Integral (PI) controller was used here to maintain the constant voltage profile for various loads at the terminals of the electric motor. Combination of PI and MFB controllers has given closed loop operation of the entire model with smooth switching between the sources. The total circuit has been simulated in MATLAB/Simulink and obtained the satisfactory results, which are discussed in the results section.

KEYWORDS: Hybrid Energy Storage System, Hybrid Electric Vehicle, Electric Vehicle, Battery, UltraCapacitor, Boost Converter, Buck-Boost Converter, Math Function Based Controller, Proportional Integral (PI) Controller.

1. INTRODUCTION

Day-to-day the demand for EV/HEV is increasing drastically due to several reasons like pollution in the atmosphere and for reducing the use of conventional fuel resource. Generally, all vehicles are driven by IC engines only and this needs petrol/diesel for its successful operation. These traditional IC engine vehicles are not eco-friendly in nature [1-5]. All above reasons for using IC engine is demanding an alternative for transportation purpose. At starting, scientists have replaced conventional sources with fuel cells and batteries to protect the environment and for a better transportation facility. But this attempt has not given expected results and is a grief to some hindrances like driving range limit [6-10]. To improve the performance of an electric vehicle, battery or fuel cell has been combined with UC. Batteries are having high energy density and low power densities, on the other hand UC has lower energy density and high-power density.

Based on Karush-Kuhn-Tucker conditions the real-time controller has been developed for HESS [1], a neural network-based strategy is implemented as an intelligent controller and an adaptive energy

management control with an integrated variable rate-limit function is described for an energy storage system [2] and also using fuzzy logic. Combining battery and UC forms a new energy source termed as HESS [10]. With this HESS, vehicle gives better performance than a single source and it improves the state of charge of the battery [6]. In case of HESS, switching between the sources are very important [8-9]; Because according to the vehicle dynamics only the transition between two sources should be done and that will be accurate and quick. That means switching of sources plays a key role in vehicle performance that is the reason why this work mostly is concentrated on the designing of a controller for good transition between the sources. Here MFB controller has been designed for the proper transition between two sources and this controller works depending upon the speed range of the motor. This MFB controller operated for four modes of operation of the motor and these four modes are categorized based on the speed value only.

2. HYBRID ENERGY STORAGE SYSTEM

Batteries and UCs give the electrical output in DC form only but they differ in their working principle. Battery and UCs have quite opposite characteristics. UCs having high power density and lower energy density, on other hand battery has quite opposite character [7]. UCs are more capable to give good results during the low-temperature period and it requires less time for charging and discharging, life period of the UC is more compared to a battery. So the combination of these two sources gives good performance over the previous system.

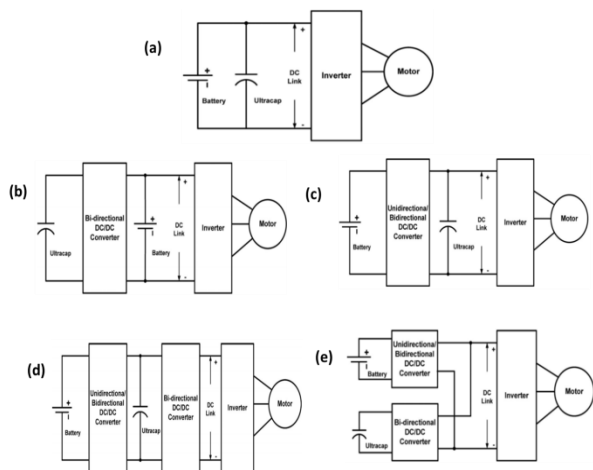

Fig. 1. (a) Conventional paralleling of sources, (b) UC-Battery model, (c) Battery-UC model, (d) Cascaded model, (e) Multiple Converter models.

2.1. Conventional Paralleling of Sources

Figure 1 shows that conventional paralleling of sources is the easiest way. Here UC and battery both are connected in parallel and again this combination output simply connect to DC link directly. So this combination simply looks like a parallel circuit that means all the voltages are equal. In this case, ultracapacitor acts as a low pass filter [9]. This type of configuration is very easy to design because of no need to struggle about designing of controllers part and do not have any power electronic circuitry. But with this configuration, we cannot utilize the advantage of the ultracapacitor.

2.2. UC-Battery Model configuration

Figure 2 shows that UC-Battery model here integration of UC and battery can do by the bidirectional converter and the voltage value of UC can use up to the wide range. To meet higher power requirements, big size converter is needed [9]. Here DC link voltage is fixed because the battery is directly connected to the link.

2.3. Battery-UC Model

Figure 3 shows that battery-UC model and here integration of battery and UC can be done by unidirectional converter [5]. UC is connected directly to the DC link, and it acts as a low pass filter. Here UC power was used effectively than the previous model because DC link voltage value can change within the specified values.

2.4. Cascaded Model

Figure 4 shows that the cascaded models, in these two separate converters are required, one are unidirectional and another one is bidirectional [4]. The unidirectional converter is connected between battery and UC, on another hand bidirectional converter is used to integrate to DC link.

2.5. Multiple Converter Models

Figure 5 shows that the multiple converter models, in these two separate converters are required, one is unidirectional and another one is bidirectional [3]. Generally, the bidirectional converter is used to integrate the UC to DC link, on another hand unidirectional converter is used to integrate battery to DC link. With this configuration it achieves better performance that means maximum utilization of UC can happen.

3. HYBRID ENERGY STORAGE SYSTEM DESIGN

This section deals with considerations which are the development of battery/UC discussed in detail. The basic design considered in the HESS topologies is discussed in detail [8].

3.1. Battery Model

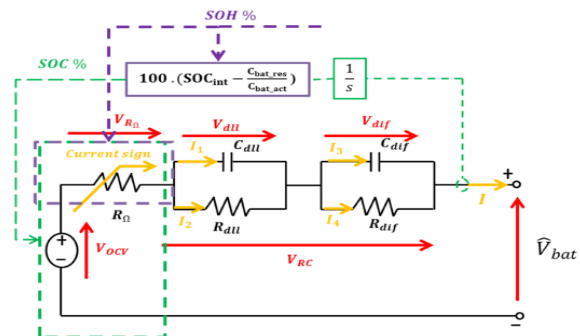

Fig. 2. A dynamical model of a battery.

The figure shows the dynamical model of the battery, where the terminal voltage is a function of time and can be found from 3 components [7]-[10].

- The source V_{OCV} tells about open circuited value, and this is directly proportional to SOC of the battery.

•The voltage drop in terminal of the circuit can be modelled from the resistor R_{Ω} and this resistance is directly related to the SOC of the battery

• Voltage drop due to $R_{dul}C_{dul}$ and $R_{dif}C_{dif}$ models simulates the polarization progression of the battery [8].

$$V_{bat} = V_{OCV} + V_{R\Omega} + V_{RC} \quad (1)$$

Voltage across the battery at terminals is given below. State of charge of battery is given by

$$SOC = 100. \left(SOC_{int} - \frac{1}{Q_n} \int \eta I_b dt \right) \quad (2)$$

Voltage across internal resistance of battery is

$$V_{R\Omega} = I_b \cdot \frac{x_{14}}{\sqrt{SOC+x_{15} \cdot SOC \cdot sign(I_b)}} \quad (3)$$

3.2. Ultracapacitor Model

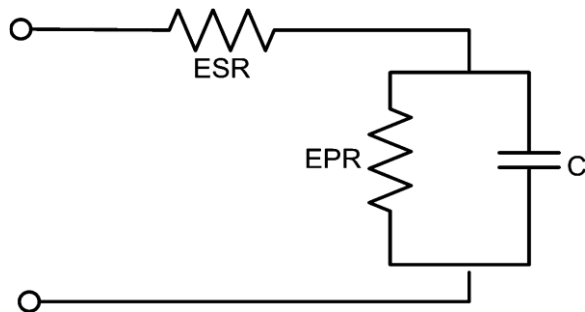

Fig. 3. Equivalent electrical model of UC.

Figure 7 represents the equivalent electrical model of UC. The voltage state of UC for RC is given by [9]

$$V(t) = V_i \exp\left(-\frac{t}{RC}\right) \quad (4)$$

Here RC represents time constant value. Ultracapacitor bank energy required can be found from

$$E_{UC} = \frac{1}{2} C (V_i^2 - V_f^2) \quad (5)$$

3.3. DC /DC Converter Model

(i). Boost Converter Modeling

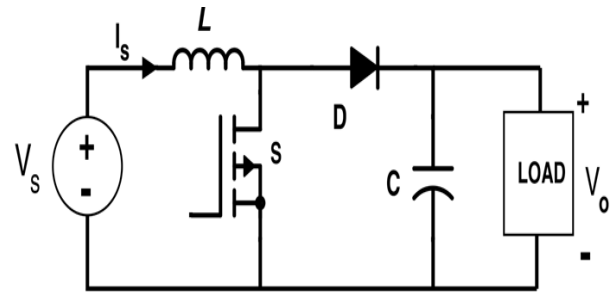

Fig. 4. DC-DC Converter (Boost).

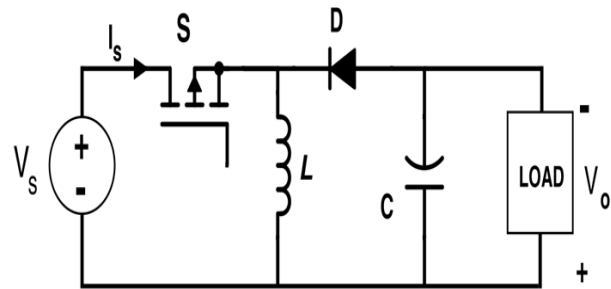

Fig. 5. DC-DC Converter (buck/boost).

Figure 8 represents DC-DC Converter (boost), and the state space expression for DC-DC converter (boost) during switch is in ON condition and is [6]

$$\begin{cases} \frac{di_L}{dt} = \frac{1}{L} (V_{in}) \\ \frac{dv_o}{dt} = \frac{1}{C} \left(-\frac{v_o}{R} \right) \end{cases} \quad 0 < t < DT, Q: ON \quad (6)$$

During OFF condition is,

$$\begin{cases} \frac{di_L}{dt} = \frac{1}{L} (V_{in} - v_o) \\ \frac{dv_o}{dt} = \frac{1}{C} \left(i_L - \frac{v_o}{R} \right) \end{cases} \quad DT < t < T, Q: OFF \quad (7)$$

(ii) Buck-Boost Converter Modeling

Figure 9 represents DC-DC Converter (buck/boost), and the state space expression for DC-DC converter (boost) during switch is in ON condition is

$$\begin{cases} \frac{di_L}{dt} = \frac{1}{L} (V_{in}) \\ \frac{dv_o}{dt} = \frac{1}{C} \left(-\frac{v_o}{R} \right) \end{cases} \quad 0 < t < DT, Q: ON \quad (8)$$

During OFF condition is,

$$\begin{cases} \frac{di_L}{dt} = \frac{1}{L} (V_o) \\ \frac{dv_o}{dt} = \frac{1}{C} \left(-i_L - \frac{v_o}{R} \right) \end{cases} \quad DT < t < T, Q: OFF \quad (9)$$

4. PROPOSED MODEL

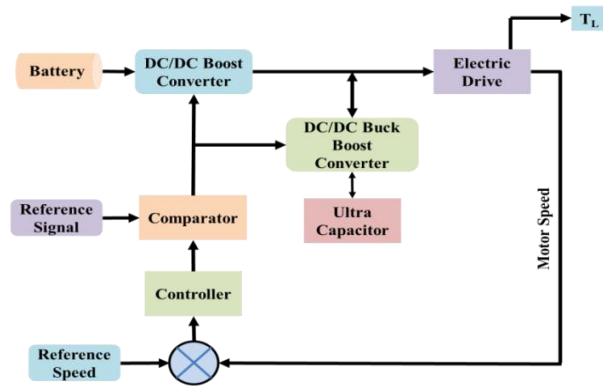

Fig. 6. The proposed block diagram model for hybrid energy storage system.

The block diagram above represents proposed model of the work. In these, two sources are combined, giving energy to the electric motor to propel the vehicle [5]. Generally, the battery is the main storage system and it is capable to serve the required average power to the electric motor. The ultracapacitor is capable of giving the energy during transient periods of the electric motor [4]. Combination of the two sources gives good results for Electric Vehicles/Hybrid Electric Vehicles. Here controller can generate the required pulses to the converters based on the speed tracking of the motor.

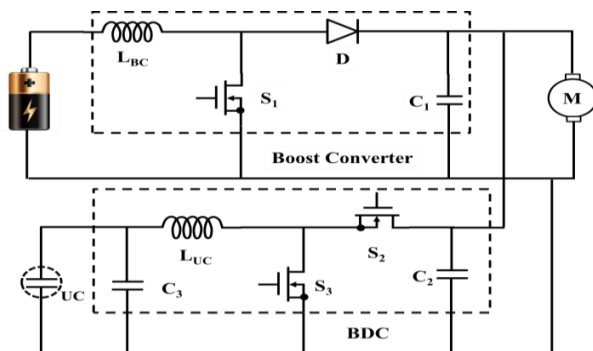

Fig. 7. Converter main circuit diagram with HESS.

Figure 7 represents the converter model of hybrid energy storage system. Here Buck and Buck/Boost (BDC) converter model has been preferred with MOSFET switches. One of the converters is connected to the battery end and another converter is connected at UC end. UC end connected converter is a BDC and battery end connected is Boost converter. During peak power requirements of the motor, BDC acts as a Boost converter, remain cases act as Buck converter for charging from the battery that means UC is mending for only to reduce the extra burden on the battery during the transient conditions[7]. The battery is

preferred here to supply the average power to the motor and it always is in the ON condition except some extreme conditions like during cold starting conditions. To achieve preferable control of energy storage system, overall circuit can be resolved into four subcircuits.

5. MODES OF OPERATION

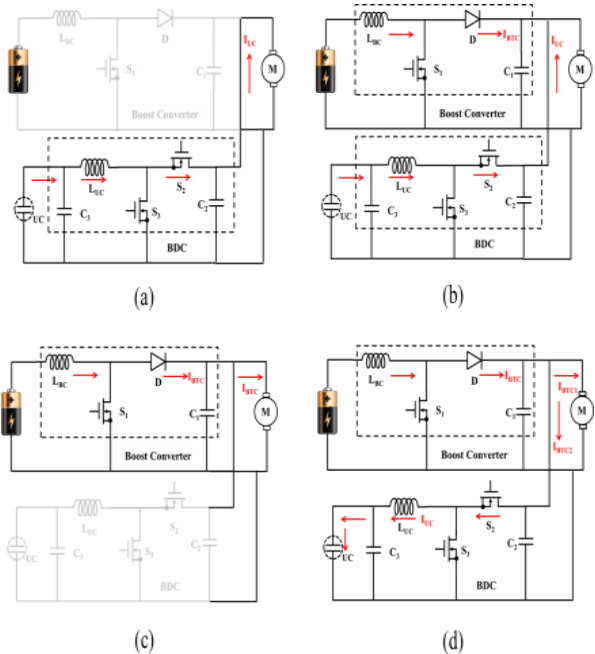

Fig. 8. (a).Converter model1 circuit diagram with HESS, (b).Converter mode2 circuit diagram with HESS, (c).Converter mode3 circuit diagram with HESS, (d).Converter mode 4 circuit diagram with HESS.

5.1. Mode-1 Operation

Mode I is related to the heavy load on the motor, switch S_3 only operates and remaining switches S_1, S_2 are in OFF position. Total power flows from battery to motor through switch S_3 , so in this mode of operation BDC acts as a boost converter and this converter operation is controlled by the pulse signals, generated by the controller based on the speed of the electric motor.

5.2. Mode-2 Operation

Mode II is related to the medium load on the motor, switches S_1 and S_3 operate and remaining switch S_2 is in OFF position. Power flows between battery to motor and UC to a motor that means BDC acts as a boost converter which is connected to ultracapacitor. In the same way battery is connected through boost converter and this also supplies power to the motor. Finally, UC and battery combination supplies power to the electric motor.

5.3. Mode-3 Operation

When the load on the motor is rated, then Mode III can be used. In this mode of the operation, switch S1 is only closed and remaining two switches are in open mode condition. That means entire energy required by the motor can be supplied only by the battery. So there are no pulse signals generated by the controller to BDC.

5.4. Mode-4 Operation

In this mode of operation the switches S1 and S2 are in closed position and switch S3 is in OFF position. This mode of operation is motor running under no load condition, so battery can supply energy to the motor as well UC for its charging purpose. Here BDC worked in buck mode.

6. CONTROL STRATEGY APPROACH

The motor rotates at the expected speed and has a certain amount of power request. As for the battery, it only works in a specific area to guarantee the optimum efficiency. If battery output power matches the requirement of the motor, the battery will be the only source to supply the loads. If there is a difference between battery supply and the motor demand, the UC will fill in the gap. It can be categorized into four modes of operation.

during this period the speed of the motor is ≤ 4800 RPM. The converter operates based on all math function generated signals. The converters in operation are the boost converter at the UC end.

(2) When the power demanded by the load is beyond the designed range of the battery output power, UC will assist the battery to deliver power to the motor. In this mode of operation, motor speed is from 4600 RPM to 4800 RPM; hence MFB generates U_1 and U_2 pulse signals as 1 and generates U_3 and U_4 pulse signals as 0. The converters in operation are the boost converter at the battery end and the boost converter at the UC end.

(3) When battery output power matches the desired power of the motor, the battery will only supply the power to the motor. In this mode of operation, the speed of the motor is from 4801 RPM to 4930 RPM. Hence MFB generates U_2 and U_3 pulse signals as 1 and generates U_1 and U_4 pulse signals as 0. At this time, only the boost converter at the battery terminal works.

(4) When battery provides more power than the motor need, the extra power will be used to charge the UC; so the power of the battery will flow into both the UC and the motor. In this mode of operation, motor speed is >4931 RPM. Hence MFB generates U_2, U_3 and U_4 pulse signal as 1 and generates U_1 pulse signals as 0. According to the converters designed, the boost converter at the battery end and the buck converter at the UC end will work in this scenario.

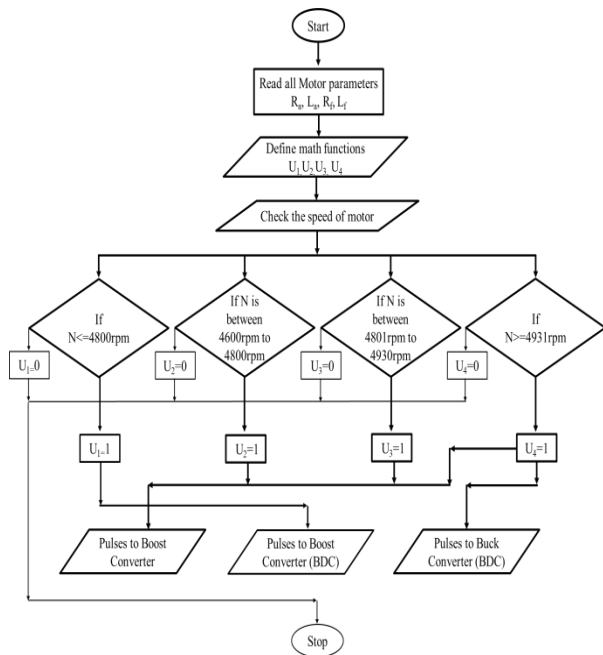

Fig. 9. The Flowchart representation of control strategy.

(1) During starting of a motor and heavy loaded condition, UC supply the power to the load. In this mode, the math function U1 gives signal value 1 and remaining all math functions generate signal 0 because

7. SIMULATION RESULTS AND DISCUSSIONS

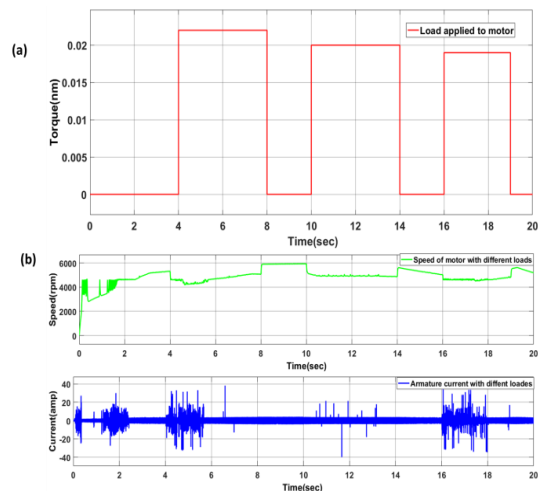

Fig. 10. (a). The load applied to the motor. (b) Speed and current curve variations with respect to the load.

From Figure 10 it is clear that load on the motor is present at different intervals with different values. From 4 to 8sec heavy load has been applied on the

motor, between 10 to 14 sec medium load and between 16 to 19sec normal loads applied on the motor. According to the load variations, the speed of the motor also is changing. Subsequently, the armature current of the motor also is changing with load variations. During the loaded conditions, speed of the motor reduces and the armature current value increases and remaining time electric motor maintains the rated speed and rated current values.

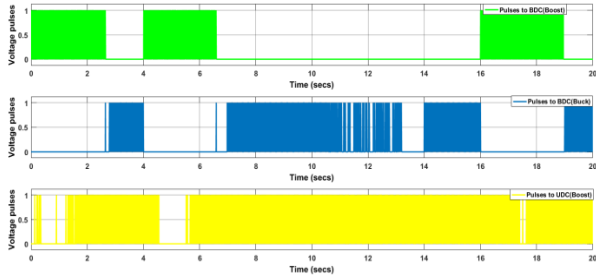

Fig. 11. Pulses generated by controllers to the unidirectional converter as well as a bidirectional converter.

During heavy load and starting of the electric motor ultracapacitor only supply required power to the motor so corresponding to this mode BDC converter operates in Boost mode. Normal mode condition battery and ultracapacitor together supply power to the motor, DC works in Boost mode and also UDC. Rated load condition battery only supplies the required power to the motor, only UDC works in Boost mode. During no-load condition, battery supplies power to motor as well as an ultracapacitor, BDC works as a Buck converter and UDC as Boost converter.

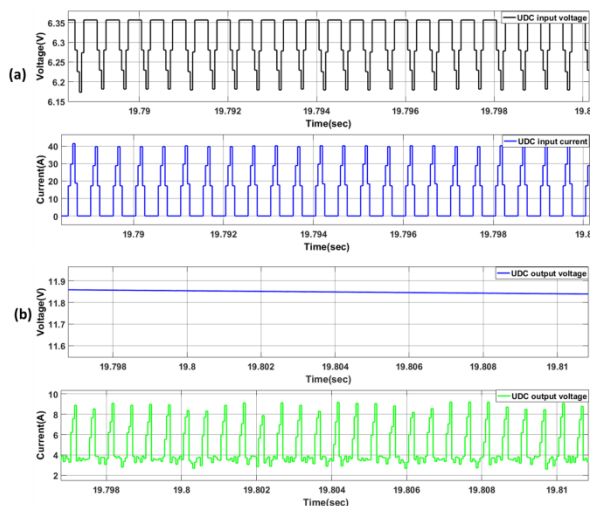

Fig. 12. (a).input voltage and current values of UDC, (b) Output voltage and current values of UDC.

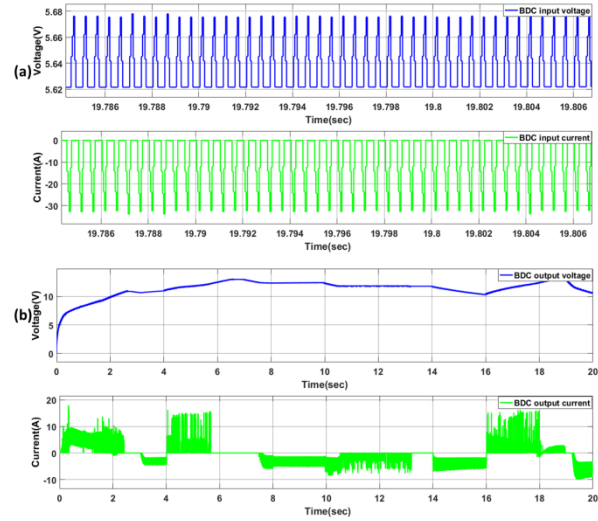

Fig. 13. (a). Input voltage and current values of BDC, (b) Output voltage and current values of BDC.

Table 1. Operation of the converter based on mode.

Mode Condition	UDC	BDC	Mode of Operation
Mode-1	Off	Boost	Power flow UC to Motor
Mode-1	Boost	Boost	Power flow UC+Battery to Motor
Mode-1	Boost	Off	Power flow Battery to Motor
Mode-1	Boost	Buck	Power Flow to Motor and UC From Battery

Table 2. State of Math Function based on the speed of the motor.

Condition Based on Speed of the Motor	State of Math Function
If Speed is ≤ 4800 RPM	Math function $U_1=1$
If Speed is from 4600 RPM To 4800 RPM	Math function $U_2=1$
If Speed is from 4801RPM To 4930 RPM	Math function $U_3=1$
If Speed is >4931 RPM	Math function $U_4=1$

8. CONCLUSION

The designed MFB controller reacted quickly to the corresponding speed of a motor. During heavy load condition, MFB controller generated a pulse signal as 1 to U_1 ; this signal initiated the operation of BDC as a Boost converter at UC end. During more than rated load condition MFB generates a pulse signal as 1 to U_1

and U_2 , this combination starts the operation of the Boost converter at Battery end and also BDC as a Boost converter at UC end. During rated load condition, MFB generated a pulse signal as 1 to U_2 U_3 , this combination made to operate only Boost converter at the Battery end. During no-load operation of the motor, MFB generated a pulse signal as 1 to U_4 and U_1 ; this initiates the operation of Boost converter at battery end and BDC as a Buck converter at UC end.

REFERENCES

- [1] J. Shen, A. Khaligh, "Design And Real-Time Controller Implementation For A Battery Ultracapacitor Hybrid Energy Storage System", *IEEE Transactions on Industrial Informatics*, Vol. 12(5), pp. 1910-8, 2016.
- [2] D. Wu, R. Todd, A. J. Forsyth, "Adaptive Rate-Limit Control For Energy Storage Systems", *IEEE Transactions on Industrial Electronics*, Vol. 62(7), pp. 4231-40, 2015.
- [3] C. Xiang, Y. Wang, S. Hu, W. Wang, "A New Topology And Control Strategy For A Hybrid Battery-Ultracapacitor Energy Storage System", *Energies*, Vol. 7(5), pp. 2874-96, 2014.
- [4] A. Sciarretta, L. Serrao, P. C. Dewangan, P. Tona, E. Bergshoeff, C. Bordons, and L. Champa, "A Control Benchmark On The Energy Management Of A Plug-In Hybrid Electric Vehicle", *Control Eng. Practice*, Vol. 29, pp. 287-298, 2014.
- [5] Y. C. Fong , X. D. Xue, S. R. Raman, K. W. E. Cheng and X. L. Wang, "Investigation Of Energy Distribution And Power Split of Hybrid Energy Storage Systems In Electric Vehicles," *International Symposium on Electrical Engineering*, Hong Kong, pp. 1-7, 2016.
- [6] K. Saichand, V. John, "Generalized Design Of Passive Components For Ultracapacitor-Based Bidirectional Dc-Dc Converters," *IEEE Annual India Conference*, Bangalore, pp. 1-6, 2016.
- [7] P. Golchoubian, N. L. Azad, "Real-Time Nonlinear Model Predictive Control of a Battery-Supercapacitor Hybrid Energy Storage System", in *Electric Vehicles. IEEE Transactions on Vehicular Technology*, Vol. 66(11), pp. 9678-88, 2017.
- [8] H. Gualous, P. Van Den Bossche ,O. Capron, N. Omar ,A. Samba, and J. Van Mierlo "Battery Thermal Modelling - Assessment Of Heat Distribution And Optimization Of Battery Design Concept," *International Conference on Renewable Energy Research and Applications*, Madrid, pp. 304-309, 2013.
- [9] A. Emadi, J. Cao , "New Battery/Ultra Capacitor Hybrid Energy Storage System for Electric, Hybrid, and Plug-In Hybrid Electric Vehicles", *IEEE Transactions On Power Electronics*, Vol. 27, No. 1, pp. 122 132, 2012.
- [10] A. M. Hava, H. H. Eroglu, "Design And Implementation of An Ultracapacitor Test System," *IEEE International Symposium on Industrial Electronics*, Gdansk, pp. 194-199, 2011.