

# Energy Storage Technologies for Smart Grid: A Comprehensive Review

Surender Reddy Salkuti  
Woosong University, Daejeon, Republic of Korea.  
Email: salkuti.surenderreddy@gmail.com

Received: December 2018

Revised: April 2019

Accepted: July 2019

## ABSTRACT:

In the recent days, the main challenge for the electrical power system is an economical storage technology. Energy storage is essential for the future Smart Grid (SG) to smooth out the fluctuating output of Renewable Energy Resources (RERs). Even though many good storage technologies are available but either they are not economical or they are not efficient. Several research studies are analyzed the application of energy storage with respect to voltage support, peak shaving, frequency stability, renewable firming, transmission upgrade deferral, and a host of other uses. RERs are dependent on the climate conditions for the power output. Therefore, an efficient storage technology is an important part for the reliability of electric power system. This paper compares different storage technologies available, i.e. hydrogen storage, batteries, superconducting magnet energy storage, fly wheels, compressed air energy storage, pumped hydro energy storage, etc. This paper details the necessity of storage techniques to help the RERs power output in the SG to meet the energy demands of the future.

**KEYWORDS:** Energy Storage, Renewable Energy Resources, Smart Grid, Batteries, Flywheels, Pumped Hydro Energy Storage.

## 1. INTRODUCTION

The concerns about energy security, climate change, and diminishing fossil fuel reserves are stimulating ever increasing interest in generation, distribution, and management of renewable power generation. Renewable Energy Resources (RERs) such as wind power and solar PV power are often inherently variable and spatially distributed, requiring the use of computational methods to predict levels of supply and demand, coordinate power distribution and manage the operations of storage facilities. The solution to this problem is the concept of a Smart Grid (SG). Energy storage is the key component for creating sustainable energy systems. Energy storage technologies have the potential to offset the uncertainty problem of RERs by storing the generated intermittent energy and then making it accessible upon demand [1]. The uncertain nature of RERs and unpredictable variable load demands have necessitated the inclusion of energy storage devices in the SG environment [2]. Energy storage technologies are the only solution for this energy sustainability problem. These energy storage technologies will have a vital role in combination of RERs in modern electrical power systems and SG [3].

Europe has set ambitious targets for renewable energy, several European countries are already nearing the 2050 goal of 50% penetration of RERs. With

greater reliance on renewable energy comes a need to represent and proactively handle their uncertainty and intermittency. To meet this challenge, several new market and operational designs have been put forth, based on explicitly including renewable uncertainty in the market clearing or operational formulation. The U.S. Department of Energy seeks to achieve 35% of total electricity generation with wind energy by 2050 in order to reduce dependence on fossil fuels [4].

The central role of energy storage devices in modern electrical systems clearly appears by the analysis of relevant scientific literature and the interests of power industry in exploiting the feasible applications. The interest in energy storage relies on the variety of benefits it can provide to different stakeholders involved along the entire value chain of the electrical system. Relevant examples of benefits achievable thanks to the use of energy storage systems refer to their potential contribution in terms of power quality and reliability improvement, capacity support and deferral of investments, provision of ancillary services, regulation, and price arbitrage. In addition, beneficial effects can be derived in case of end-user applications in terms of reduction of costs related to energy consumption and peak demand. Furthermore, the energy storage systems are particularly useful for allowing network integration of intermittent RERs in

order to meet the modern tendency aimed at increasing the share of renewable power in the production of electrical energy.

The major point is that the energy storage technologies are the basis of the future of SG. Without adequate storage techniques, there will be no way to reliably meet the energy demands of the future. The current storage technologies that will be explored in the present paper include pumped hydro energy storage, flywheels, compressed air energy storage, batteries, superconducting magnetic energy storage system, supercapacitors and hydrogen storage. Each storage technologies will be classified by its features, cost, modelling, advantages and disadvantages. When deciding which storage technique is best to build, it is important to evaluate each based on its characteristics.

Distributed generation networks are excellent power grid networks that can be used to address a grid power quality challenges by the incorporation of storage systems (e.g., flywheels and super-capacitors,) and equipment usable as a power conditioner [5]. The study on micro grid loads, energy storage devices, power electronic interface modules, interfaced distributed energy resources, and the interconnection of multiple micro grids is presented in [6]. The concept of combining the applications into attractive value propositions that includes the use of energy storage, possibly including distributed systems is presented in [7]. In Reference [8], a smart energy management algorithm is proposed for the hybrid energy storage system supplied from 3-phase 4-wire grid connected Photovoltaic (PV) power system. Reference [9] presents the review of the scientific literature within the field of smart energy systems with regard to the issues of definition, identification of solutions, modelling, and integration of storage. Reference [10] presents a broad insight into different electrical energy storage technologies, their applications, challenges to widespread deployment, and future trends and outlooks. Reference [11] proposes a Virtual Energy Storage System (VESS) and shows that the VESS is a cost-effective way to provide the function of energy storage through the utilization of flexible load demand. Reference [12] analyses the storage strategies to simultaneously satisfy the heat and electricity demand through the efficient use of distributed generation units under the demand response mechanisms. An optimal battery storage capacity for the SG operation is presented in [13].

Reference [14] analyses the current and potential future of electricity storage systems in SG technically and economically. The solution of joint energy storage ownership sharing between the multiple shared facility controllers and those dwelling in a residential community is presented in [15]. A hierarchical setup in which a central controller is responsible for managing

the flexibilities of industrial thermal loads via a contract based direct control policy is proposed in [16]. An approach which jointly optimizes the energy charged/discharged to/from the shared energy storage system given a profit coefficient set that specifies the desired proportion of total profit allocated to each user, subject to practical constraints of the system is proposed in [17]. Reference [18] presents the effects of battery charging and discharging on the battery life and the energy cost. A smart electrical power system in which users are equipped with energy storage devices is proposed in [19].

Reference [20] presents an interdisciplinary review of community energy storage with a focus on its potential role and challenges as a key element within the wider energy system. A wide spectrum of energy policies regarding the electrochemical, mechanical, and thermal energy storage technologies have been addressed in [21]. Reference [22] examines the dynamic operation and control strategies for a microgrid hybrid wind-photovoltaic-fuel cell based power supply system. By producing the electricity produced by the renewable energy sources, it effects the increment of both energetic costs, due to reduced efficiency operation, and wear-and-tear costs. This aspect is deeply analyzed in [23] with reference to the Italian electricity generation mix in the period 2008–2012. A hybrid bird-mating optimization approach to connection decisions of distribution transformers is proposed in [24]. Reference [25] proposes a Novel Intelligent Damping Controller (NIDC) for the static synchronous compensator to reduce the power fluctuations, voltage support and damping in a hybrid power multi-system. A novel unsymmetrical faults analysis method with hybrid compensation for microgrid (MG) distribution systems is proposed in [26]. Reference [27] presents the ground fault model of a battery energy storage system as a distributed energy resource, which can be used for both islanded and grid-connected modes. Reference [28] addresses the role of energy storage in cooling applications.

Recently, the advanced technologies such as rechargeable batteries based graphene, two dimensional material, and plasmonic systems are also playing important roles in the smart grid. The lithium-based rechargeable batteries including lithium-ion and lithium-sulfur have attracted much attention for lithium possessing the extremely high energy density. The carbonaceous materials play a vital role as carbon electrodes and key components for the lithium-based rechargeable batteries. The unique two-dimensional spatial structure gives graphene excellent electrical conductivity, physical properties and huge specific surface area. These make graphene a very promising material for energy storage applications [29-30]. Lithium-ion batteries have dominated the portable

electronics industry and solid-state electrochemical research and development for the past two decades. In light of possible concerns over the cost and future availability of lithium, sodium-ion batteries and other new technologies have emerged as candidates for large-scale stationary energy storage. Recently, the two-dimensional materials are showing promise for many energy-related applications and particularly for energy storage, because of the efficient ion transport between the layers and the large surface areas available for improved ion adsorption and faster surface redox reactions [31].

The goal of the present paper is to present different storage technologies and their comparison for the use in Smart Grid (SG) environment. It aims to gather the latest research on state-of-the-art energy storage technologies modeling and analysis.

The remainder of the paper is organized as follows: Section 2 presents description of various types of energy storage technologies for the SG environment. The comparison of different storage technologies is presented in Section 3. Contributions with concluding remarks have been presented in Section 4.

## 2. TYPES OF ENERGY STORAGE TECHNOLOGIES

Storage techniques will play a huge part in the future of power generation. The high level benefits that will be felt from energy storage techniques are as follows [32]:

- *Reducing reserve power plants:* Reserve power plants are set-up to shave peak demands. It is desirable to reduce the number of reserve power plants. Moreover, the conventional reserve power plants are non-environmentally friendly because of the dirty fossil fuels that power the plants. Whereas, the energy storage techniques can both store power during demand valleys and shave peak demand with low emissions.
- *Reducing costs associated with power outages:* Power outages are a huge problem because they affect many facets of our world. In many power outages, businesses cannot operate. However, the storage devices can provide power until back-up power is made available. Utility companies that serve areas that often lose service can delay making short-term improvements by implementing storage techniques and concentrating on making better, more strategic long term improvements to their SG.
- *Supporting for RERs:* With the addition of storage techniques, RERs can reduce the variability in power output. Specifically, wind and solar PV power, because these are currently the most sustainable RERs.

Different storage techniques available are presented

next [32]:

### 2.1. Batteries

Batteries can be found in many different forms which include lithium ion, sodium-sulfur, flow, and lead acid. Because of their high cost and/or short lifetime, they are only used in a limited number of applications. Batteries are portable and could be placed almost anywhere. Banks of lead-acid batteries are commonly used to stabilize electrical systems by supplying extra power and maintaining voltage and frequency levels. Lead acid batteries have very low life spans when charged and discharged frequently. Flow batteries store electrolytes outside itself and circulate these electrolytes to generate the electricity. Since these batteries create a substrate but are not involved in any chemical reaction, the flow batteries have long life spans. Nickel-metal hydrides have relatively low energy densities and are very sensitive. They tend to have problems with overcharging. Rural locations utilize portable sodium-sulfur battery systems to provide power for small time periods. Lithium-ion (Li-ion) are commonly used in cell phone and laptop computers. In comparison with nickel-cadmium and lead acid batteries, they have a much higher energy density. Their long lifetimes make them a very good cost option. Manufacturing of batteries poses as huge safety and environmental risk due to the large number of chemicals involved [33].

Owing to their flexible geographical placement and relatively low footprint, battery storage systems plays a key role for providing the electricity buffer for the future SG [34]. The lead-acid battery is modelled as,

$$t = \frac{Q_P}{I^{k1}} \quad (1)$$

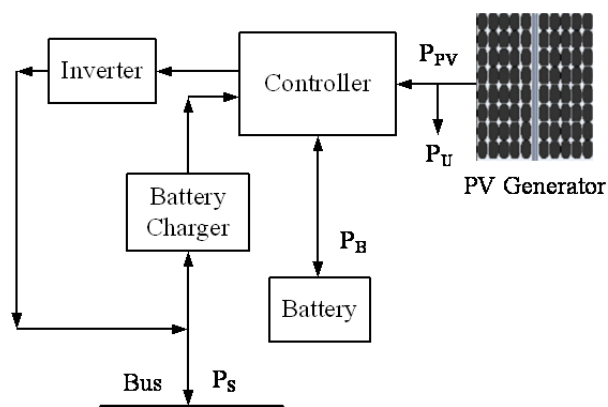

**Fig. 1.** Grid connected solar energy system with battery storage.

Fig. 1 depicts the grid connected solar energy system with battery storage. The main advantages of energy storage batteries include: high discharge

duration at maximum power level, low self-discharge rate, shapes and sizes vary to meet any requirement, they are lighter, environmentally friendlier, reduces the carbon emission from the vehicles. However, the main drawbacks of storage batteries include: high charge levels, relatively low efficiency, elevated temperatures that quicken capacity loss, high internal resistance that increases as it gets older. The cost of batteries varies depending on the type of battery chosen. At the low end, alkaline batteries cost \$190/kWh. At the high end, nickel-cadmium batteries cost \$1500/kWh [35]. The cost of the Li-ion battery is estimated to be about \$150/kWh by 2020.

## 2.2. Flywheels

A spinning disk on a metal shaft represents the storage location of a flywheel system. Increasing the speed of rotation, mass of the disk, or moving the mass closer to the rim of the disk increase a flywheel's storage capacity. Flywheels are most often used for applications requiring short discharge time. These types of applications normally refer to voltage and frequency stabilization. The flywheel is a very versatile energy storage device. It is constructed with a rotor suspended by magnetic or mechanical bearings and rotates inside a vacuum chamber (to reduce friction), all within a shell for safety. This is then connected to a system (usually a generator), and based on the principle of conservation of energy, the flywheel stores the energy when it spins and supplies energy when needed. When the flywheel is charging, it accelerates to speeds from 20,000 rpm to about 50,000 rpm.

The modelling of flywheel takes into account that energy is stored in the rotating mass within the flywheel. In other words, the Kinetic Energy (KE) which is either transferred in or out of the flywheel contains the rotational energy possessed by the rotating mass. When the flywheel is in the motor mode of operation, electric energy supplied to the stator winding is converted to torque and applied to the rotor, causing it to spin faster and gain the KE. In generating mode of operation, the KE stored in the rotor applies a torque, which is converted into the electric energy. The equation for the KE stored in the flywheel is expressed as,

$$E_K = \frac{1}{2} I \omega^2 \quad (2)$$

Moment of inertia is a function of shape. Therefore, for a cylindrical rotor,

$$I = \frac{1}{2} r^2 m = \frac{1}{2} r^4 \pi \alpha \rho \quad (3)$$

Hence, the maximum energy of a flywheel rotor is expressed as,

$$\frac{E}{m} = K_2 \left( \frac{\sigma}{\rho} \right) \quad (4)$$

The cost of flywheels is approximately \$1250/kWh [36]. The advantages of flywheels include: very fast response time, handling of high power levels, high efficiency and power density. However, the risk of flywheel explosion creates the need for stronger containment vessels and the flywheels have relatively low discharge time at the maximum power level.

## 2.3. Pumped Hydro Energy Storage

This type of storage facilitates energy storage in the form of water in an upper reservoir, pumped from another reservoir at a lower elevation. During time periods when electricity is inexpensive, water is pumped to the elevations where the water is stored in a reservoir. When the demand for power is high, the water is released and allowed to push hydroelectric turbines which generate electricity. New developments in pumps and turbines have led to variable flow rates which have increased the efficiency of this storage technique. The pumped hydro energy storage method is very straightforward, and can be seen as a modification of regular hydroelectric dams. The operation of this storage system is explained below:

- In times of low electricity demand, the excess available energy is used to pump water to a higher reservoir.
- The pumped water which now possesses gravitational potential energy is stored at a high point in the reservoir till the energy is needed.
- In periods of peak energy demand (and higher cost of electricity), the water is then released from the top of the reservoir and used to turn the turbine to produce electricity.

The important part of this model is the conversion of potential energy of the water as it drops from the source over a height into electrical power. The modelling of pumped hydro energy storage system is presented next:

Potential energy is given by,

$$E = mgh \quad (5)$$

Relating power to mass flow rate is given by,

$$\frac{E}{t} = \frac{m}{t} gh \quad (6)$$

Therefore, for the hydro-electric power,

$$P = \rho \phi gh \quad (7)$$

$$P = hrgk_3 \quad (8)$$

The cost of a pumped hydro storage system is about \$1500/kWh of capacity [37]. The pumped hydro storage system should be located in a place that can allow for the water to be raised to a considerably high elevation. Pumped hydro energy storage system is a well-developed storage system, and it is important because of its capability to handle very large power, covering a range from about 200MW to 2000MW.

#### 2.4. Compressed Air Energy Storage (CAES) System

The CAES system utilizes high efficiency compressors to store air underground. Like most storage techniques, the energy is stored during low cost, low demand time periods. When the electricity demands, the air expands to atmospheric pressure which causes turbines to generate electricity that can be used by the SG. CAES system is found to be a viable solution to store the energy generated from the wind and other RERs. A detailed review on various aspects of a CAES system has been made and described in [38].

The basic principle of operation of CAES system is that the energy is stored during the off-peak periods of demand in underground formations' or caverns. These caverns are either created by solution mining or by using an abandoned mine. In periods of peak demand for power, most often during the day, the stored compressed air is then heated and used to drive a steam turbine. The modelling for CAES system primarily aims to show how the air is compressed, as well as how the compressed air is used to generate the electricity. The compression is given by the following equation,

$$P_c = \frac{1}{n_c} m C_p \left[ \left( \frac{p_2}{p_1} \right)^{\frac{k_4-1}{k_4}} - 1 \right] \quad (9)$$

The compressed air also follows the ideal gas laws giving by the following equation,

$$pV = nRT \quad (10)$$

This produces the energy (work) to drive the turbine, and it is expressed as,

$$W = p_B p_A \ln \frac{p_A}{p_B} \quad (11)$$

According to the Electric Power Research Institute (ERPI), the price of tis storage is about \$1000 per kWh [38]. The advantages of CAES system include; high energy storage capacity, high discharge duration at maximum power and high power output. However, the slow response time is the main drawback of the CAES system.

#### 2.5. Superconducting Magnetic Energy Storage (SMES) System

The SMES system involves storing the energy within a magnetic field. As the name implies, it consists of a superconducting material which essentially has a zero resistance, and allows the DC current to pass through freely in its field. Electric current is stored indefinitely inside of superconducting windings. Moreover, SMES has the capability to quickly discharge high power for brief time spans. Larger coils correspond to more power capacity. As the coils become larger, the magnetic field increases. At a point, the superconducting properties of the windings begin to break down and the coolant is necessary to keep the machine operable that is very expensive. The model for the SMES system has to account for the energy stored in the coils, and it is expressed as,

$$E = \frac{1}{2} LI^2 \quad (12)$$

SMES system holds a lot of potential as an energy storage system. While operating at medium voltages, it is capable of discharging up to 3MW, indicating a lot of upside for larger industrial applications. Furthermore, it is very high efficient which makes it a truly viable option but until further developments are made in discovering more economically efficient superconductors, its implementation will be limited. For a toroidal design, the cost of SMES is approximately \$2000/kWh of storage capacity. The advantages of SMES include: fast response time, high efficiency and long lifespan. However, the major drawbacks include: low storage capacity, low power output and low discharge duration at maximum power level [39].

#### 2.6. Supercapacitors

Supercapacitors store energy using two oppositely charged electrodes which are separated using an ionic solution. Energy is stored when ions attach to the electrodes and released when ions return to the solution. The modelling for the supercapacitor aims to address the amount of energy stored in a capacitor. The capacitance of a capacitor is directly proportional to the common surface area of plates and inversely proportional to distance between the plates, and it can be expressed as,

$$C = \epsilon_R \epsilon_0 \frac{A}{d} \quad (13)$$

The stored energy in a capacitor is expressed as,

$$W_{stored} = \frac{1}{2} CV^2 \quad (14)$$

Where,  $W_{\text{stored}}$  is the energy stored (in Joules). The cost of supercapacitors is approximately (2400-6000) \$/kWh of storage capacity. The advantages of supercapacitors include: fast response time, high efficiency and long lifespan. The disadvantages include: low energy storage capacity, low power output and low discharge duration at maximum power level [40].

### 2.7. Hydrogen Storage

It is one of the divisions of hydrogen powered vehicles technology [41]. Electrolytic hydrogen offers a promising alternative for long-term energy storage of renewable energy [41]. Hydrogen storage is a key enabling technology for the advancement of fuel cell and hydrogen technologies in applications including portable power, stationary power, and transportation. Hydrogen has the highest energy per mass of any fuel. However, its low ambient temperature density results in a low energy per unit volume. Hence, there is a

requirement for the development of advanced storage methods that have potential for higher energy density.

Hydrogen can be stored physically as either a liquid or a gas. High density hydrogen storage is a challenge for portable and stationary applications and remains a significant challenge for transportation applications. Presently available storage methods require large-volume systems that store hydrogen in gaseous form. This is less of an issue for stationary applications, where the footprint of compressed gas tanks may be less critical [42]. In the future, the hydrogen storage is able to demonstrate a substantial contribution to the electricity sector [43].

### 3. COMPARISON OF DIFFERENT ENERGY STORAGE TECHNOLOGIES

In this section, various energy storage technologies are compared based on their principle of operation, advantages and disadvantages, and they are presented in Table 1.

**Table 1.** Comparison of different Energy Storage Technologies.

Storage Technology	Principle of Operation	Advantages	Disadvantages
<b>Batteries</b>	One or more electrochemical cells convert the chemical energy to electrical energy.	<ul style="list-style-type: none"> <li>• High round-trip efficiency.</li> <li>• Convenient charging/discharging</li> <li>• It takes care of the effects caused by instantaneous load ripples/spikes, electrolyzer transients, wind energy peaks, etc.</li> <li>• Relatively inexpensive and fairly reliable.</li> <li>• Quick charging and discharging.</li> </ul>	<ul style="list-style-type: none"> <li>• It cannot be used as seasonal storage.</li> <li>• Low energy density.</li> <li>• Self discharge and leakage.</li> <li>• It is not suited to supply pulse power output.</li> <li>• Voltage fluctuates and cannot provide large currents for long time.</li> </ul>
<b>Flywheels</b>	Flywheel energy storages work by accelerating a rotor at very high speed and maintain the energy in the system as rotating energy. When energy is extracted from the system, flywheel's rotational speed is reduced as consequence of principle of conservation of energy. Similarly, adding the energy into the system will result exactly reverse condition.	<ul style="list-style-type: none"> <li>• Higher storage capacity and discharge rate compared to batteries and other form of energy storage.</li> <li>• It can be used for load leveling along with battery.</li> <li>• It can store and release energy quick so it can be used for pulsed power applications.</li> <li>• It does not affect adversely by temperature, so it operates in wide ranges of temperature.</li> <li>• It has indefinite working life span.</li> <li>• It is very eco-friendly technology.</li> </ul>	<ul style="list-style-type: none"> <li>• It has higher maintenance cost due to continuous involvement of moving part.</li> <li>• It has design limitation with respect to tensile strength.</li> <li>• It has energy loss involved as friction loss.</li> </ul>
<b>Pumped Hydro Energy Storage</b>	Energy is stored in water form, pumped from lower elevation reservoir to higher elevation. During the periods of	<ul style="list-style-type: none"> <li>• It is the only useful storage technology for large scale industrial applications.</li> <li>• It is an economical method as it flattens out load variations in</li> </ul>	<ul style="list-style-type: none"> <li>• It has substantial time delay associated with energy conversion of stored mechanical energy back into electrical energy.</li> </ul>

	high energy demand, the stored water is released through the turbine to produce electricity.	power grid. <ul style="list-style-type: none"> <li>• New concepts is under observation of using solar or wind power for pump operation that may be proved as more efficient and smoothen out the variability involved in wind and solar power.</li> </ul>	<ul style="list-style-type: none"> <li>• Energy wasted during the pumping process.</li> <li>• Evaporation losses from the exposed water surface.</li> </ul>
<b>Compressed Air Energy Storage (CAES) System</b>	Off-peak (low cost) electrical power compresses air into an underground air storage vessel and later the air feeds a gas fired turbine generator to generate electricity during peak demand periods.	<ul style="list-style-type: none"> <li>• It has proven a very efficient technology for hybrid vehicles as compressed air can transfer power at very high flux rates.</li> <li>• Longer life span of pressure vessels and lower material toxicity.</li> </ul>	<ul style="list-style-type: none"> <li>• Pressure varies greatly while using a pressure vessel from full to empty.</li> <li>• It is technically challenging to design air engines to maintain high efficiency and sufficient power over a wide range of pressures.</li> </ul>
<b>Superconducting Magnetic Energy Storage (SMES) system</b>	SMES is an energy storage technology that stores energy in the form of dc electricity that is the source of a dc magnetic field. The conductor for carrying the current operates at cryogenic temperatures where it is a superconductor and thus has virtually no resistive losses as it produces the magnetic field.	<ul style="list-style-type: none"> <li>• It is over 90% efficient (including refrigeration losses) whereas pumped hydro, batteries and flywheel were typically (60-70)% efficient.</li> <li>• SMES provide high and very fast power current to suppress load fluctuation.</li> <li>• It has high power density.</li> <li>• Available power is almost instantaneous and very high power output can be obtained over brief time period.</li> <li>• Very low power loss compared to other methods as electrical currents experience negligible resistance.</li> <li>• High reliability in lieu of no moving parts.</li> </ul>	<ul style="list-style-type: none"> <li>• It has lower energy density compared to batteries and flywheel.</li> <li>• It is costly as energy requirements of refrigeration and high cost of super conducting wire.</li> </ul>
<b>Supercapacitors</b>	It is an electrochemical capacitor with relatively high energy density. Two separate plates separated by intervening insulator.	<ul style="list-style-type: none"> <li>• It has very long life compared to other storage technologies.</li> <li>• Good reversibility.</li> <li>• Very high rate of charge and discharge.</li> <li>• High efficiency and low heating levels.</li> <li>• Improved safety, no corrosive electrolyte, and low toxicity of materials.</li> </ul>	<ul style="list-style-type: none"> <li>• Energy storage per unit is lower than battery.</li> <li>• It has higher dielectric absorption of any type of capacitor.</li> <li>• High self discharge rate.</li> <li>• Low maximum voltage – serial connections are needed to obtain higher voltages.</li> </ul>
<b>Hydrogen Storage</b>	The energy produced is sent to the electrolyzer for hydrogen production. When there is need for stored energy, the stored hydrogen is fed to a fuel cell to produce electricity.	<ul style="list-style-type: none"> <li>• It is well suited for Seasonal Storage</li> <li>• High inherent mass energy density leakage from storage tank that is insignificant</li> <li>• Easy to install anywhere in the system</li> <li>• Useful for remote power applications.</li> </ul>	<ul style="list-style-type: none"> <li>• It cannot be used as short term energy storage</li> <li>• Low energy efficiency.</li> <li>• Durability of hydrogen storage is inadequate.</li> <li>• Weight and volume of this system is very high.</li> </ul>

**4. COST-BENEFIT ANALYSIS**

Based on the billions and trillions of dollars that governments and utility companies spend on energy yearly, the importance of efficient energy storage techniques cannot be overemphasized. None of the presented storage technologies (Compressed Air Energy Storage (CAES), Flywheels, Batteries, Pumped Hydro Energy Storage, Supercapacitors and Superconducting Magnetic Energy Storage) has proven to be able to address the issue as a standalone solution. However, it remains to be seen how the major stakeholders, governments and utilities alike, prioritise their focus on the various techniques.

For a well-rounded cost analysis, the starting point will be the capital costs, i.e., the cost of complete installation of a storage system. These vary widely between the different methods as they are made of different components such as the high temperature super conductor for the flywheel and the low temperature superconductor for the SMES system.

The benefits of developing this initiative though may seem initially outweighed by overwhelming start-up costs, but these projects can be sure to reap huge dividends in the medium and long-term despite heavy research and development costs. Table 2 presents the estimated costs for some of the storage methods. Cost-Benefit analysis for different storage technologies has been presented in Table 3.

**Table 2.** Estimated costs for storage methods.

Technology	Cost (\$/kW)
CAES	700
Pumped Hydro	2,250
Lithium-Ion Battery	1,100
Flywheels	1,250
Flow batteries	2,500

**Table 3.** Cost-Benefit Analysis for Different Storage Technologies.

Storage Technology	Cost (\$/kWh)	Capacity (MWh)	Duration (Hrs)
CAES	600-700	1440-3600	8-20
SMES	1270	20	2
Flywheel	7800-8800	5	0.25
Super Capacitor	2000	3	6-8
Pumped Hydroelectric	100	1680-5300	6-10

**5. CONCLUSIONS**

This paper presents different energy storage technologies and their applications to the Smart Grid (SG). These energy storage technologies include

flywheels, batteries, pumped-hydro storage, compressed air storage, supercapacitors, hydrogen storage and superconducting magnetic energy storage (SMES). More recent approaches towards energy storage are more direct and sophisticated especially with the rise of smart grid technology. The general idea here is to find suitable ways by which to combine some forms of central storage, such as flywheel with some distributed storage like lithium-ion batteries in order to achieve some form of load balancing in their smart grid. Storage devices make sure that energy is used efficiently and whatever is not used is stored for a later use. After doing the comparison among various storage techniques, it can be concluded that the best way is to use these storage devices is through the hybridization. This is to prevent dependence on only one form of storage. Every storage technique has its own advantages and disadvantages. Therefore, the storage technology to be used for a particular application is chosen accordingly.

**6. NOMENCLATURE**

- Q<sub>P</sub> Capacity of a battery when discharged at a rate of 1A.
- I Current drawn from the battery (in A).
- t Time (in hours) that a battery can sustain.
- k<sub>1</sub> Constant.
- E<sub>K</sub> Kinetic Energy (KE) stored in the flywheel.
- I Moment of inertia.
- ω Angular velocity.
- r Radius
- m Mass of the cylinder.
- ρ Density of the cylinder material.
- σ Tensile strength of material (in Pa).
- ρ Material's density (in kg/m<sup>3</sup>).
- K<sub>2</sub> Rotor's geometric shape factor.
- P Hydroelectric power (in KW).
- E Energy (in J).
- m Mass (in kg).
- g Acceleration due to gravity (in m/s<sup>2</sup>).
- ρ Density of water.
- φ Rate of fluid flow.
- k<sub>3</sub> Coefficient of efficiency.
- P<sub>c</sub> Input power to the compressor.
- n<sub>c</sub> Overall efficiency of the compressor.
- m Mass flow rate of the air.
- p<sub>2</sub> Pressure at outlet of compressor.
- p<sub>1</sub> Pressure at inlet of compressor.
- k<sub>4</sub> Specific heat ratio of air (C<sub>p</sub>/C<sub>v</sub>).
- V Volume.
- n Amount of gas (in mol).
- R Ideal gas constant.
- T Absolute temperature.
- ε<sub>r</sub> Relative permittivity.
- ε<sub>0</sub> Dielectric constant.
- d Separation between the plates.



## REFERENCES

- [1] Overview of storage technologies. Available. [Online]: <http://www.h2020-project-sensible.eu/documents/overview-of-storage-technologies.pdf>
- [2] U.K. Debnath, I. Ahmad, D. Habibi, A.Y. Saber, "Energy Storage Model with Gridable Vehicles for Economic Load Dispatch in the Smart Grid," *International Journal of Electrical Power & Energy Systems*, Vol. 64, pp. 1017-1024, Jan. 2015.
- [3] E. Ozdemir, S. Ozdemir, K. Erhan, A. Aktas, "Energy Storage Technologies Opportunities and Challenges in Smart Grids," *International Smart Grid Workshop and Certificate Program*, Istanbul, 2016, pp. 1-6.
- [4] P. Du, N. Lu, "Energy Storage for Smart Grids, Planning and Operation for Renewable and Variable Energy Resources (VERs)," *Elsevier Inc.*, 2014.
- [5] J.A. Momoh, S. Meliopoulos, R. Saint, "Centralized and Distributed Generated Power Systems - A Comparison Approach," *Future Grid Initiative White Paper*, Power Systems Engineering Research Center, Jun. 2012.
- [6] R. Bayindir, E. Hossain, E. Kabalci, R. Perez, "A Comprehensive Study on Microgrid Technology," *International Journal of Renewable Energy Research*, Vol. 4, No. 4, pp. 1094-1107, 2014.
- [7] J. Eyer, G. Corey, "Energy Storage for the Electricity Grid: Benefits and Market Potential Assessment Guide," *A Study for the DOE Energy Storage Systems Program*, February 2010. Available. [Online]: [https://www.smartgrid.gov/files/sandia\\_energy\\_storage\\_report\\_sand2010-0815.pdf](https://www.smartgrid.gov/files/sandia_energy_storage_report_sand2010-0815.pdf)
- [8] [https://www.smartgrid.gov/files/sandia\\_energy\\_storage\\_report\\_sand2010-0815.pdf](https://www.smartgrid.gov/files/sandia_energy_storage_report_sand2010-0815.pdf)
- [9] A. Aktas, K. Erhan, S. Ozdemir, E. Ozdemir, "Experimental Investigation of a New Smart Energy Management Algorithm for a Hybrid Energy Storage System in Smart Grid Applications," *Electric Power Systems Research*, Vol. 144, pp. 185-196, Mar. 2017.
- [10] H. Lund, P.A. Østergaard, D. Connolly, B.V. Mathiesen, "Smart energy and smart energy systems," *Energy*, May 2017.
- [11] B. Pinnangudi, M. Kuykendal, S. Bhadra, "Smart Grid Energy Storage," *The Power Grid, Smart, Secure, Green and Reliable*, pp. 93-135, 2017.
- [12] M. Cheng, S. SabahSami, J. Wu, "Virtual Energy Storage System for Smart Grids," *Energy Procedia*, Vol. 88, pp. 436-442, Jun. 2016.
- [13] P.C.D. Granado, Z. Pang, W. Wallace, "Synergy of Smart Grids and Hybrid Distributed Generation on the Value of Energy Storage," *Applied Energy*, Vol. 170, pp. 476-488, May 2016.
- [14] H.O.R. Howlader, H. Matayoshi, T. Senjyu, "Distributed Generation Integrated with Thermal Unit Commitment Considering Demand Response for Energy Storage Optimization of Smart Grid," *Renewable Energy*, Vol. 99, pp. 107-117, Dec. 2016.
- [15] N. Kutucu, Ü.K. Terzi, H.Y. Ayirga, "Technical and Economic Analysis of Energy Storage Systems in Smart Grids," *5th International Istanbul Smart Grid and Cities Congress and Fair*, Istanbul, Turkey, 2017, pp. 166-170.
- [16] W. Tushar, W. Tushar, B. Chai, C. Yuen, S. Huang, D.B. Smith, H.V. Poor, Z. Yang, "Energy Storage Sharing in Smart Grid: A Modified Auction-Based Approach," *IEEE Trans. Smart Grid*, Vol. 7, No. 3, pp. 1462-1475, May 2016.
- [17] S. Rahnama, J.D. Bendtsen, J. Stoustrup, H. Rasmussen, "Robust Aggregator Design for Industrial Thermal Energy Storages in Smart Grid," *IEEE Trans. Smart Grid*, Vol. 8, No. 2, pp. 902-916, Mar. 2017.
- [18] K. Rahbar, M.R.V. Moghadam, S.K. Panda, T. Reindl, "Shared Energy Storage Management For Renewable Energy Integration in Smart Grid," *IEEE Power & Energy Society Innovative Smart Grid Technologies Conference*, Minneapolis, MN, 2016, pp. 1-5.
- [19] J. Klaimi, R. Rahim-Amoud, L. Merghem-Boulahia, A. Jrad, M. Esseghir, "An Intelligent Storage-based Energy Management approach for Smart Grids," *IEEE 12th International Conference on Wireless and Mobile Computing, Networking and Communications*, New York, NY, 2016, pp. 1-7.
- [20] H.K. Nguyen, J.B. Song, Z. Han, "Distributed Demand Side Management with Energy Storage in Smart Grid," *IEEE Trans. Parallel and Distributed Systems*, Vol. 26, No. 12, pp. 3346-3357, Dec. 2015.
- [21] D. Parra, M. Swierczynski, D.I. Stroe, S.A. Norman, A. Abdon, J. Worlitschek, T.O'Doherty, L. Rodrigues, M. Gillott, X. Zhang, C. Bauer, M.K.Patel, "An Interdisciplinary Review of Energy Storage for Communities: Challenges and Perspectives," *Renewable and Sustainable Energy Reviews*, Vol. 79, pp. 730-749, Nov. 2017.
- [22] G.L. Kyriakopoulos, G. Arabatzis, "Electrical energy storage systems in Electricity Generation: Energy Policies, Innovative Technologies, and Regulatory Regimes," *Renewable and Sustainable Energy Reviews*, Vol. 56, pp. 1044-1067, Apr. 2016.
- [23] T.C. Ou, C.M. Hong, "Dynamic operation and control of microgrid hybrid power systems," *Energy*, Vol. 66, pp. 314-323, Mar. 2014.
- [24] L. Barelli, U. Desideri, A. Ottaviano, "Challenges in Load Balance due to Renewable Energy Sources Penetration: The Possible Role of Energy Storage Technologies Relative to the Italian Case," *Energy*, Vol. 93, No. 1, pp. 393-405, Dec. 2015.
- [25] T.C. Ou, W.F. Su, X.Z. Liu, S.J. Huang, T.Y. Tai, "A Modified Bird-Mating Optimization with Hill-Climbing for Connection Decisions," *Energies*, Vol. 9, No. 9, pp. 1-12, 2016.
- [26] T.C. Ou, K.H. Lu, C.J. Huang, "Improvement of Transient Stability in a Hybrid Power Multi-System Using a Designed NIDC (Novel Intelligent Damping Controller)," *Energies*, Vol. 10, No. 4, 2017.
- [27] T.C. Ou, "A Novel Unsymmetrical Faults Analysis for Microgrid Distribution Systems," *International Journal of Electrical Power & Energy Systems*, Vol. 43, No. 1, pp. 1017-1024, Dec. 2012.

- [28] T.C. Ou, "Ground Fault Current Analysis with a Direct Building Algorithm for Microgrid Distribution," *International Journal of Electrical Power & Energy Systems*, Vol. 53, pp. 867-875, Dec. 2013.
- [29] G. Comodi, J.Y. Sze, N. Balamurugan, A. Romagnoli, "Storing Energy for Cooling Demand Management in Tropical Climates: A Techno-Economic Comparison Between Different Energy Storage Technologies," *Energy*, Vol. 121, pp. 676-694, Feb. 2017.
- [30] L. Qin, "Applications of Graphene in Lithium-based Rechargeable Batteries," *3rd International Conference on Smart Materials and Nanotechnology in Engineering (SMNE 2016)*, pp. 63-66, 2016.
- [31] Available. [Online]: <https://arxiv.org/ftp/arxiv/papers/1403/1403.2161.pdf>
- [32] L. Peng, Y. Zhu, D. Chen, R.S. Ruoff, G. Yu, "Two-Dimensional Materials for Beyond-Lithium-Ion Batteries," *Advanced Energy Materials*, Vol. 6, No. 11, pp. 1-21, Jun. 2016.
- [33] R. Howes, S. Mtingwa, "Challenges of Electricity Storage Technologies," *Panel on Public Affairs*, May 2007.
- [34] Available. [Online]:
- [35] [https://eurobat.org/sites/default/files/eurobat\\_smartgrid\\_publication\\_may\\_2013.pdf](https://eurobat.org/sites/default/files/eurobat_smartgrid_publication_may_2013.pdf)
- [36] A. G. Wang, "Battery Energy Storage System: The key of Future Smart Grid," *IEEE International Conference on Pervasive Computing and Communication Workshops*, Sydney, NSW, 2016, pp. 1-1.
- [37] "Battery Energy: What Battery Provides More?," Available. [Online]:
- [38] <http://www.allaboutbatteries.com/Battery-Energy.html>
- [39] S. Nasr, "How Grid Energy Storage Works," *HowStuffWorks*, <http://science.howstuffworks.com/environmental/green-tech/sustainable/grid-energy-storage6.htm>
- [40] D. Link, "Pumped Hydro: Part of the Solution to our Energy Storage Needs," *Pike Research*, Sept. 2010.
- [41] G. Venkataramani, P. Parankusam, V. Ramalingam, J. Wang, "A Review on Compressed Air Energy Storage – A Pathway for Smart Grid and Polygeneration," *Renewable and Sustainable Energy Reviews*, Vol. 62, pp. 895-907, Sept. 2016.
- [42] M.S. Guney, Y. Tepe, "Classification and Assessment of Energy Storage Systems," *Renewable and Sustainable Energy Reviews*, Vol. 75, pp. 1187-1197, Aug. 2017.
- [43] V. Kumar, S. Park, K. Parida, V. Bhavanasi, P.S. Lee, "Multi-Responsive Supercapacitors: Smart solution to Store Electrical Energy," *Materialstoday Energy*, Vol. 4, pp. 41-57, Jun. 2017.
- [44] K. Agbossou, M. Kolhe, J. Hamelin, T.K. Bose, "Performance of a Stand-Alone Renewable Energy System Based on Energy Storage As Hydrogen," *IEEE Trans. Energy Conversion*, Vol. 19, No. 3, pp. 633-640, Sept. 2004.
- [45] Available. [Online]:
- [46] <https://energy.gov/eere/fuelcells/hydrogen-storage>
- [47] S. Lazarou, S. Makridis, "Hydrogen Storage Technologies for Smart Grid Applications," *Challenges*, Vol. 8, No. 1, pp. 1-11, 2017.