

Real-time Stability Assessment of Power System using ANN without Requiring Expert Experience

Hamid Ghadiri

Department of Electrical, Biomedical and Mechatronics Engineering, Qazvin Branch, Islamic Azad University, Qazvin, Iran.
Email: h.ghadiri@qiau.ac.ir

Received: May 2019

Revised: August 2019

Accepted: November 2019

ABSTRACT:

Nowadays, power systems should be operated in the highest level of utilization and near their stability limits because of economic reasons. So stability assessment of the power system to determine the stability limits has been always considered. In SCADA/EMS systems a constant value called security margin and steady-state stability limit are used to determine transient stability limit instead of time-domain simulation. The security margin that is almost constant for power systems is determined experimentally. In this article this constant is computed using a probabilistic neural network and this method is implemented on IEEE 39 bus. As a result, the performance of this neural network is suitable for this application.

KEYWORDS: Power System Stability, Transient Stability Limit, Steady-State Stability Limit, Security Margin.

1. INTRODUCTION

Three different types of solution techniques that have been implemented in power system control centers, to address the needs for real-time stability assessment, are transient stability, voltage stability, and steady-state stability. In modern power control centers, three different MW utilization limits by using these techniques are monitored that are called transient stability limit, voltage stability limit, and steady-state stability limit.

Voltage Stability Limit and Steady-State Stability Limit (SSSL) can be monitored in real-time but calculating the Transient Stability Limit (TSL) in real-time is impossible because many scenarios should be considered. To overcome this problem in SCADA/EMS systems (for example in Romania, Bosnia and Herzegovina, etc.), a value called security margin is used. This value is almost constant for each power system and is determined experimentally. For example, this value was 20% for the Romanian power system in the 1970s [1]. The experiment cannot be a good solution to determine this value because it is important for suitable network utilization. In this article, the security margin is computed using a neural network. After computing security margin for once and SSSL in a short second, TSL can be monitored in real-time.

To determine the security margin using ANN, transient stability limit should be computed at the first. To compute transient stability limit, load and generation should be increased step by step and in each step, severe contingencies are assessed and stability of power system

is determined [2]. Power system stability in a specified state is determined using ANN. The MW utilization in the state before transient instability is transient stability limit. After computing the transient stability limit and steady-state stability limit for some utilization cases, the total security margin is computed by averaging the security margins of these cases. This constant can be used to control the network and prevent blackouts using load shedding.

2. STABILITY LIMITS

The stability limit equals to the minimum of transient stability limit, steady-state stability limit and voltage stability limit [1]. Between these limits, transient stability limit is more constraint than others. To compute security margin in this section, transient stability limit and steady-state stability limit are explained.

2.1. Steady-State Stability Limit

The Steady-State Stability Limit of a power system is an operating condition for which the power system is steady-state stable but an arbitrarily small change in any of the operating quantities in an unfavorable direction causes the power system to lose stability. This limit can be defined as the stability of the system under conditions of gradual or relatively slow changes in load [3].

Violating system operating constraints called 'Security Constraints' or diverging of load flow is a steady state instability condition of an operating state. These constraints ensure that the power in the network is properly balanced as given by equation (1) [4], bus

voltage magnitudes and thermal limit of transmission lines are within the acceptable limits given by equation (2) [4].

$$\sum_{i=1}^{N_g} P_{Gi} = P_D + P_{Loss} \quad (1)$$

$$P_{Gi}^{min} \leq P_{Gi} \leq P_{Gi}^{max}$$

$$|V|_k^{min} \leq |V|_k \leq |V|_k^{max}, k = 1.2 \dots N_b \quad (2)$$

$$S_{k-m} \leq S_{k-m}^{max} \quad \text{for branches } k - m$$

Where, P_{Gi} represents real power generation at bus i , P_D is the system demand; P_{Loss} is the total real power loss in the transmission network; $|V|_k$ is the voltage magnitude at bus; S_{km} represents complex power flow in branch $k - m$; N_g and N_b are the number of generators and buses respectively [4].

The steady-state stability limit for an initial state of the power system can be calculated by increasing load and generation until the security Constraints violate. After computing SSSL, the distance between this critical state and MW utilization in % Called stability reserve is calculated using Equation (3) [1].

$$\text{Stability Reserve} = \frac{SSSL - P_{base-case}}{SSSL} \times 100 \quad (3)$$

The amount of SSSL is calculated in a few seconds in SCADA/EMS systems using a practical technique called "DIMO Algorithm" [1] and SSSL is monitored in a specified period of time to avoid the risk of blackout due to instability. The base of Dimo Algorithm is the diverging of load flow that is used in this article.

2.2. Transient Stability Limit

The contingency analysis technique is a prerequisite to predict the effects of various contingencies like the failure of transformers, transmission lines, etc. It helps to initiate necessary control actions to maintain power system security, reliability, and stability [5].

To find Transient Stability Limit, if the base case is transient stable for all the contingencies, the operation condition of the system should be stressed by increasing load and generation and in each step, all the transient computations should be repeated until a state system becomes instable for one or some contingency and also MW utilization in one state before this insecure state is transient stability limit. If the base case was instable, then the system condition should be relaxed by decreasing load and generation and in each step, all the transient computations should be repeated until a secure state is found then the MW utilization in this state is transient stability limit [1].

The amount of MW utilization in a state equals the sum of MW generation and tie-line imports and also this amount equals the sum of MW loading and losses and tie-line exports [6].

After calculating TSL, the security margin in percent is computed using Equation (4) [1].

$$\text{Security Margin} = \frac{SSSL - TSL}{SSSL} \times 100 \quad (4)$$

States that for them, stability reserve is bigger than security margin, are safe states as shown in Fig.1[1] and for these states, no contingency, no matter how severe, would cause transient instability.

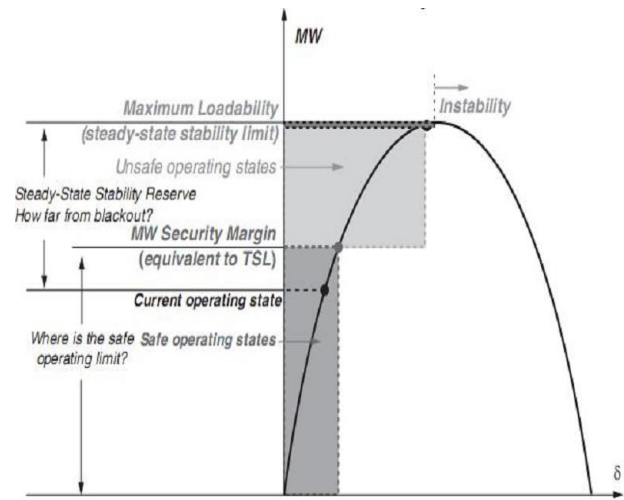

Fig. 1. Secure and Insecure operation states.

3. RELATIONS BETWEEN TRANSIENT STABILITY LIMIT AND STEADY STATE STABILITY LIMIT

There are the following relations between TSL and SSSL:

1. These two limits depend on system topology, voltage levels, and loading [6].
2. TSL is always smaller than SSSL and when SSSL increases/decreases, so do TSL [6].
3. The experiments show that the amount of TSL/SSSL is almost constant [1].

The security margin is almost constant because TSL/SSSL is constant [1]. Between these two limits, monitoring of TSL is more difficult but with a given experimental value of security margin, it is possible to monitor TSL. In this article, the amount of security margin is obtained more accurate using ANN instead of only using experiments. To obtain this value, firstly stability of a state should be determined that is done in section 4.

4. ANALYZING TRANSIENT STABILITY USING NEURAL NETWORK

To train a neural network that is able to determine the stability of a state, first utilization patterns of network operational space are produced and each of them is evaluated for different contingencies, a pattern is transient unstable if it is unstable for at least one disturbance.

4.1. Producing Suitable Utilization Patterns

To have a good interpolation for ANN, the operation space of the power system should be introduced to ANN. To generate training patterns, first the maximum and minimum active power of each load bus are determined and 10 loading levels between P_L^{max} and P_L^{min} for each load, bus are produced [7]. Then for each loading level, the base generation patterns are produced so there will be 10 utilization patterns including loading and generation patterns. To create more patterns, for each base case loading pattern, the MW load of buses are increased or decreased randomly between 5% to 15% for 10 times (for example), also for generation patterns, the MW generation of all generators are varied randomly between -30% to +30% for 10 times (for example) [7]. Finally, there will be 1000 utilization patterns by merging the above-produced patterns and these patterns are applied to the power system to analyze transient stability.

After power flow calculations, the load and generation patterns for which the power flow does not meet steady-state operating requirements are known as unstable [8] and no evaluations are done for them.

4.2. Evaluated Contingencies

Assumed contingencies for transient stability analyzing are:

- I. Short circuit on transmission lines: the worst types of the short circuit are at the start and end of lines [4]. This fault is removed after a short time by relays.
- II. The outage of transmission lines.
- III. The outage of generators unless slack generation unit.

If the number of transmission lines is small (for example IEEE 9 bus system) then the evaluations can be done on all lines but for a large size network, it is impossible. To overcome this problem, a performance index is used to select lines that have the most effect on instability by occurring short circuits or outage of them. This performance index that is used to sort the lines is defined in Equation (5) [9].

$$PI_1 = \max(\max(\theta_i) - \min(\theta_i)), \quad (5)$$

for $i = 1.2 \dots N_G$

$$\text{and } t_{cl} \leq t \leq t_{cl} + T$$

Where, θ is generator rotor angles relative to COI, N_G is the total number of generators, t_{cl} is fault clearance time, and T is the length of the short period after fault clearing.

4.3. Instability Criterion

Since power systems rely on synchronous machines for generating electrical power, a necessary condition for satisfactory system operation is that all synchronous machines remain in synchronicity [10]. So transient stability is the ability of the power system to maintain synchronism when subjected to a severe transient disturbance [10]. The system response to such disturbances involves the excursion of rotor angle, machine speed, bus voltages, and other system variables [10]. If the resulting variation between machines remains within certain bounds then the system is stable [10].

The instability criterion after time-domain simulations and computing output (rotor angles of generators relative to the slack generator) in a given case and for a specified disturbance is whether the relative angle of at least one generator exceeds 180 degrees in the 1 second after clearing time [4]. In this article, the critical angle is assumed 170 degrees due to utilization instructions.

4.4. Data Generation and Feature Selection

In most references, the load flow results before applying contingencies such as magnitude and angle of bus voltages, active and reactive power of generators, active and reactive power of loads, active power flow of lines are selected for neural network input data. In some references, the dynamic variables are selected too but, in this research, just the load flow results are used due to the following results:

1. No improvement of results was found by selecting dynamic variables [11], [12].
2. Because of the increasing size of different contingencies special for large size networks, it is impossible to add dynamic variables.
3. Just the load flow, obtained from the SCADA system, are accessible and no contingencies are evaluated in the practical implementing of neural networks.

After the definition of input vectors, the target vector should be defined. The target value for a specified case is "1", if the network was stable for all contingencies and "2" if it was unstable for at least one contingency.

4.5. Neural Network Architecture

A pattern recognition network is used to determine a case as stable or unstable. Many researchers have proven

that a single hidden layer of neurons, operating a sigmoid activation function, is sufficient to model any solution [13], but in real-time applications, other networks such as PNN are used for simulation because it is faster in training and testing than a MLP network.

Some solutions have been used in other references like recurrent neural network [16] and fuzzy logic [17] that have complex structures. This network may improve classification accuracy, however it increases the computation time which would affect the real-time assessment.

In this article, a PNN is used. The architecture of this network is shown in Fig. 2 [14]. When an input is presented, the first layer computes distances from the input vector to the training input vectors and produces a vector whose elements indicate how close the input is to a training input [14]. The second layer sums these contributions for each class of inputs to produce a vector of probabilities, as its net output [14]. Finally, a competitive transfer function on the output of the second layer picks the maximum of these probabilities and produces a 1 for that class and a 0 for the other classes [14].

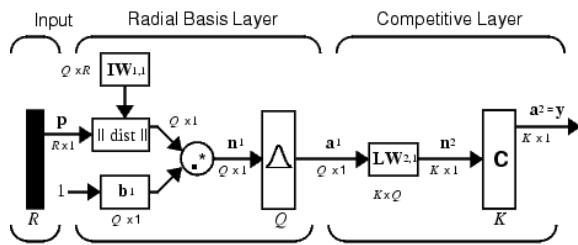

Fig.2. PNN Structure.

5. COMPUTING SECURITY MARGIN USING ANN

After training the Neural network, SSSL and TSL should be computed for each random base case. To compute SSSL first load flow is executed for the base case. if the base case was steady-state stable, load and generation should be increased stepwise, and, in each step, steady-state stability conditions are checked until instability occurs. MW utilization in a state before this critical state is SSSL.

To compute TSL, first load flow is executed and the results are applied to the neural network, if the base case was secure (neural network output was “1”), load and generation should be increased stepwise and in each step load flow results are saved and transient stability computations are repeated using the neural network until transient instability occurs (neural network output was “2”). MW utilization in a state before this insecure state is TSL. Otherwise, if the base case was insecure then load and generation should be decreased stepwise, and, in each step, transient stability computations are

repeated using the neural network until the network becomes stable (neural network output was “1”). MW utilization in this secure state is TSL. After computing, TSL and SSSL for each pattern security margin are calculated using Equation (4).

6. SIMULATION RESULTS FOR IEEE 39 BUS

Single line diagram of IEEE 39 bus (New England), the parameters of machines, lines, and transformers, thermal limits of lines in MVA are given in reference [15]. This network that is shown in Fig.3 [15] has 10 generators, 34 transmission lines, 19 load buses. In this network G1 (on bus 39) is slack. The number of training patterns is 1330 such that 507 patterns are transient secure and others are insecure.

The evaluated contingencies are:

1. Short circuit on 0% and 100% lines from $t=0$ sec to $t=0.8$ sec.
2. Lines outage at $t=0$ sec.
3. Generators outage at $t=0$ sec.

So, the total number of scenarios for each pattern equals $111(34+34+34+9)$, and for 1330 pattern equals 147630 that is time-consuming. To overcome this problem, just lines and generators that have the most effect on instability are selected using PI index in section 2.4. To verify the selection sets, 250 operation cases were produced and time-domain simulations were done first for all lines and generators and then for selection sets and there was just 1 misclassification, but simulation time for selection sets was less, so this misclassification can be ignored.

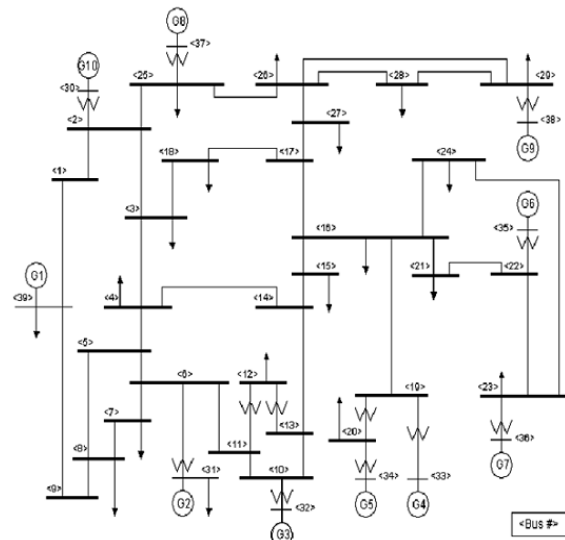

Fig. 3. IEEE 39 bus single line diagram.

Now PNN neural network is trained for transient stability assessment by using sections 3.4 and 4.4 and the

security margin is computed. For analyzing the performance of the neural network, 10 random patterns are created and TSL/SSSL is computed for them using time-domain simulation and neural network. The results are given in Table 1. The total MW generation and total MW loading for each pattern in each step is increased by 5.058 MW and 5.487 MW respectively. In this power system tie line import is 0 MW, so MW utilization is equaled the sum of MW power of generators.

The average percent of TSL/SSSL is 86.90% using time-domain simulations and 86.58% using PNN that shows PNN works properly to estimate TSL/SSSL. In

the next step, 15 random patterns are selected and PNN is used to transient stability assessment, and no transient analysis is done using time-domain simulations. Stability reserve and security margin are computed for each pattern and finally, the security margin for IEEE 39 bus system is computed by averaging these 15 security margin amounts.

These results are given in Table 2 and as shown in this Table, TSL/SSSL is equal to 87.74% and the security margin is 12.25% that is near to real amounts.

Table 1. Computing TSL using time-domain simulation and PNN.

Pattern no.	Real MW	SSSL (MW)	TSL using time-domain simulations (MW)	TSL using PNN (MW)	TSL/SSSL using time-domain simulations	TSL/SSSL using PNN
1	3939	4701	4621	5384	87.31	85.82
2	4104	4746	4746	5429	87.41	87.41
3	3989	4390	4591	5113	85.86	89.79
4	4084	5006	4885	5850	85.57	83.51
5	4126	4768	4607	5411	88.12	85.15
6	3984	4546	4666	5389	84.35	86.58
7	3386	4829	4628	5673	85.11	81.58
8	3629	4751	4791	5394	88.08	88.83
9	4070	4912	4832	5515	89.07	87.61
10	4451	4772	4852	5415	88.13	89.61
Average TSL/SSSL using time-domain simulation					86.90	
Average TSL/SSSL using PNN						86.58

Table 2. Real-time stability monitoring using PNN.

Pattern no.	Real MW	SSSL	TSL using PNN	TSL/SSSL	Stability Reserve%	Security margin%
1	5237	5237	4756	90.80	0.00	9.20
2	3479	5243	4641	88.51	33.65	11.49
3	4079	5444	4680	85.98	25.07	14.02
4	4069	5554	4791	86.25	26.74	13.75
5	5551	5551	4748	85.52	0.00	14.48
6	4423	5266	4624	87.80	16.01	12.20
7	3282	5487	4844	88.28	40.19	11.72
8	3637	5282	4639	87.83	31.14	12.17
9	3715	5240	4637	88.50	29.09	11.50
10	4765	5327	4644	87.18	10.56	12.82
11	4377	5461	4778	87.49	19.85	12.51
12	3705	5190	4627	89.16	28.60	10.84
13	3723	5248	4605	87.75	29.05	12.25
14	4023	5267	4624	87.79	23.63	12.21
15	4936	5418	4735	87.39	8.90	12.61
Average TSL/SSSL using PNN				87.74		
Average security margin						12.25

Between these patterns, patterns number 1, 5, 10, 15 are insecure and others are secure and patterns number 1, 5 are called critical stable so the probability of blackout in these 2 patterns is so high.

To evaluate the performance of the neural network, the following criteria are defined and computed:

- a) The percent of stable states that are classified as unstable:

$$\text{Insecure Misclassification (ISM\%)} = \frac{\text{Number Of 1's classified as 2}}{\text{Total Number Of Stable States}} \times 100$$

- b) The percent of instable states that are classified as stable:

$$\text{Secure Misclassification (SMC\%)} = \frac{\text{Number Of 2's classified as 1}}{\text{Total Number Of Instable States}} \times 100$$

- c) The percent of states that are classified correctly:

$$\text{Classification Accuracy (CA\%)} = \frac{\text{Number of samples classified correctly}}{\text{Total Number of samples in data set}} \times 100$$

- d) Training and testing time of neural networks.

The above criteria are computed for 10 patterns in Table 1 and the results are given in Table 3. As shown in Table 3, the percent of correct classification is high and the percent of incorrect classification is low that shows good performance of the neural network. The average of Classification accuracy is 94.4% with the method in this article while this factor is 99% in [16] and for fuzzy logic used in [17] is 99% in the best case and 84% for the worst case. This matter is due to using a neural network with memory cells and complex structures of methods used in [16] and [17]. As mentioned above, this accuracy is good and adequate in comparison with complex methods. The training and testing time for PNN was equal to 2.23 seconds that is proper for real-time applications. This time is 37.43 sec for the same system in reference [16] and so the neural network used in this article is better for real-time stability assessment.

Table 3. Performance criterions for PNN.

SMC% using PNN	ISM% using PNN	CA% using PNN
3.7162	8.3770	94.455

7. CONCLUSION

Three solution types for real-time stability assessment are the steady-state stability limit, transient stability limit, and voltage stability limit. To transient stability assessment, severe contingencies should be evaluated for each pattern that is impossible in real-time.

To overcome this problem, a constant value called security margin should be computed and according to that, TSL is computed in real-time. This constant was determined experimentally in the past but in this article neural network was used to compute this value. In this paper, PNN was used to simulate IEEE 39 bus power system. According to simulation results, the TSL/SSSL ratio and security margin for IEEE 39 bus when N elements are in the service is equal to 87% and 12%, respectively.

REFERENCES

- [1] Savulescu, S.C., "Real-Time Stability Assessment In Modern Power System Control Centers", ed. M.E. El-Hawary. 2009: Wiley. 425.
- [2] Ahmed N. Al-Masri, M.Z.A. Ab Kadir, H. Hizam and N. Mariun, "Simulation of an Adaptive Artificial Neural Network for Power System Security Enhancement Including Control Action", *Applied Soft Computing Journal, Elsevier*, 2015: p.1-11.
- [3] Atanackovic, D., Clapauch, J.H., Dwernychuk, G., Gurney, J., and Lee,H., "first steps to wide area control", *IEEE*, 2008: p. 61-68.
- [4] S. Kalyani and K. SHanti Swarup, "Study Of Neural Network Models For Security Assessment In Power Systems", *International Journal of Research and Reviews in Applied Sciences*, 2009: p. 104-117.
- [5] S.D. Naik, M.K. Khedkar, S.S. Bhat, "Effect of Line Contingency on Static Voltage Stability And Maximum Loadability in Large Multi Bus Power System", *International Journal of Electrical Power & Energy Systems, Elsevier*, 2015:p.448-452.
- [6] Savu C. Savulescu., "Fast Computation of Steady State Stability Limits for Real Time and Offline Applications", *7th International Workshop on Electric Power Control Centers*. 2003.
- [7] M.Aghamohammadi and M. Ali, "Real time Dynamic Stability Assessment of power systems Using Neural Network", *20th international electricity conference*, 2005.
- [8] Ayman Hoballah and István Erlich, "Transient Stability Assessment using ANN Considering Power System Topology Changes", *IEEE*, 2009.
- [9] S. Jadid and S. Jalilzadeh, "Application of Neural Network for Contingency Ranking Based on Combination of Severity Indices", *World Academy Of Science,Engineering And Technology*, 2005: p. 173-176.
- [10] Mahta Boozari., "State Estimation And Transient Stability Analysis In Power Systems Using Artificial Neural Networks", *Master Of Applied Science Thesis,Simon Fraser University*, 2004.
- [11] F.Aboytes and R.Ramirez, "Transient Stability Assessment In Longitudinal Power Systems Using Artificial Neural Networks", *IEEE Transactions on Power Systems*, Vol. 11, No.4, 1996, p. 2003-2010.
- [12] V.Miranda, J.N.Fidalgo, J.A.Pecas Lopes and L.B.Almeida, "Real Time Preventive Actions for Transient Stability Enhancement with a Hybrid Neural Network Optimization Approach", *IEEE-PES 1994 Summer Meeting*, 1994.

- [13] Hecht-Nielsen, “**Theory of the Backpropagation Neural Network**”, *IEEE International Conference on Neural Networks*, Vol. 1, 1989, p. 593-605.
- [14] H. Demuth, M.T Hagan and H.M. Beale, **Neural Network Toolbox for Use with Matlab**, Mathworks, Natick, Mass., 2010.
- [15] Anantha Pai, “**Energy Function Analysis for Power System Stability**”, *Springer*, 1989: p.223-225.
- [16] Yu, James Jian Qiao, et al. “**Intelligent Time-Adaptive Transient Stability Assessment System.**” *IEEE Transactions on Power Systems* (2017).
- [17] Kamwa, S. Samantaray, and G. Joos, “**On the Accuracy Versus Transparency Trade-Off of Data-Mining Models for Fast-Response Pmu Based Catastrophe Predictors,**” *IEEE Trans. Smart Grid*, Vol. 3, No. 1, pp. 152–161, Mar.2012.