

Sequential Parts Analysis Using Local Optimization Method for Hybrid Excitation Flux Switching Generator

Nur Afiqah Mostaman¹, Erwan Sulaiman², Mahyuzie Jenal²

1- Department of Electrical Engineering, Universiti Tun Hussien Onn Malaysia, Parit Raja, Malaysia.

Email: afiqahmostaman98@gmail.com (Corresponding author) 

2- Department of Electrical Engineering, Universiti Tun Hussien Onn Malaysia, Parit Raja, Malaysia.

Email: erwan@uthm.edu.my

Email: mahyuzie@uthm.edu.my

ABSTRACT:

The Hybrid Excitation Flux Switching Generator (HEFSG) has gained significant popularity in recent times owing to its relatively simple remarkably efficient topology. To optimize the performance of the generator, recent advancements and emerging patterns in mathematical modeling and software simulation, along with the utilization of optimization techniques, have facilitated the development of a novel methodology for electrical machine design. This study investigates the configuration and optimization of a Hybrid Excitation Flux Switching Generator, focusing on the rotor, armature coil, and field excitation. The optimization process involves multiple sequences for each component, employing the Local Optimization Method as an iterative approach to determine the optimal sequence that yields the highest output efficiency. Through the investigation of six rotor sequences, two armature coil sequences, and two field excitation coil sequences, a detailed optimization process was conducted. Consequently, the final output voltage of the HEFSG gains a 1.10% increment of voltage compared to the initial outcomes. Several sequences have influenced the output voltage performance of the generator during the optimization process. Therefore, modifications to the design of the arrangement contribute to the expansion of the operational range of the generator.

KEYWORDS: Optimization, HEFSG, Generator, FSG, Rotor, Armature coil, Field Excitation Coil and LOM.

1. INTRODUCTION

In the present era, there has been a significant rise in the advancement of renewable energy technologies, driven by the imperative to fully realize their potential within a global context [1]. This is characterized by the prominence of environmental regulations and the pressing need for electricity conservation [2]. As per the provisions outlined in EU Directive 2018/2001 about the usage of energy derived from renewable sources, each Member State within the European Union must set forth ambitious objectives to be achieved by the year 2030 [3]. The primary objective of these targets is to attain a renewable energy consumption level equivalent to 32.5% of the overall energy demanded [4], [5], [6].

Nevertheless, the conventional generator frequently uses a carbon brush and slip ring configuration [7]. It is important to acknowledge that the carbon brush located on the slip ring is susceptible to damage and breakdown. Hence it reduces the overall reliability of the machine, as illustrated in Fig. 1 [8]. The depicted image indicates that it can be observed that the surface of the revolving rotor is fully saturated with permanent magnets (PMs), while the armature coil is configured in a dent formation with overlapping sections. Additionally, the inclusion of a substantial quantity of rare-earth magnets. Their constructions result in the manifestation of some attributes that are identical to those observed in permanent magnet generators. The generator's durability at high speeds is compromised due to the mechanical weakness inherent in this arrangement [9].

©The Author(s) 2024

Paper type: Research paper

<https://doi.org/10.30486/mjee.2024.1998536.1290>

Received: 29 September 2023; revised: 2 November 2023; accepted: 16 December 2023; published: 1 March 2024

How to cite this paper: N. A. Mostaman, E. Sulaiman, and M. Jenal, “**Sequential Parts Analysis Using Local Optimization Method for Hybrid Excitation Flux Switching Generator**”, *Majlesi Journal of Electrical Engineering*, Vol. 18, No. 1, pp. 253-263, 2024.

Furthermore, the voltage, power, and efficiency of the existing permanent magnet generator exhibit suboptimal performance and require further enhancement due to the significant risk of permanent magnet demagnetization [10]. Moreover, an additional disadvantage associated with the utilization of magnets is the possibility of permanent demagnetization due to the operation at elevated temperatures and the presence of high stator flux [11], [12], [13]. Concerning the matter, enhancing the efficiency of the mechanical component can significantly impact the overall performance of the entire structure. Whereby augmenting the coefficient of the wind turbine leads to an increase in the power generated [14], [15].

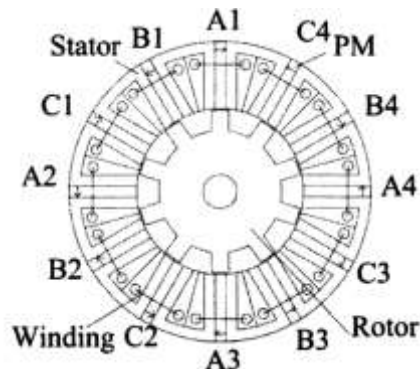

Fig. 1. Conventional design of permanent magnet generator.

In the past decade, Flux Switching Generators (FSGs) have gained significant popularity and recognition due to their utilization of a singular and uncomplicated rotor configuration, while still exhibiting exceptional performance in high-speed applications that require high mechanical speed such as electric vehicles, [16], [17]. Nevertheless, the FSG does possess several limitations, including elevated cogging torque and leakage current in comparison to conventional generators. The FSG can be classified into three distinct kinds, namely Permanent Magnet (PM) FSG [18], [19], [20], Field Excitation (FE) FSG [21], and Hybrid Excitation (HE) FSG [22], as depicted in Fig. 2. According to the figure, the HEFSG is the prevalent utilization in contemporary industrial sectors and electric vehicles. A growing body of research and development on hybrid excitation generators has garnered significant interest due to the substantial advantages and diverse configurations suggested by previous researchers [23], [24], [25]. Chen et al. stated that the hybrid excitation generator incorporates a field winding along with the conventional permanent magnet generator [26]. By retaining the benefits of a PM generator, the generator's air-gap electromagnetic field remains constant and can be modified, which makes it easy to create a consistent output voltage. However, most hybrid excitation generators have been designed for operation within a direct current (DC) circuit [27]. Consequently, incorporating additional semiconductors into these generators will not increase running costs when considering the mechanical properties acquired through extended periods of operation [28].

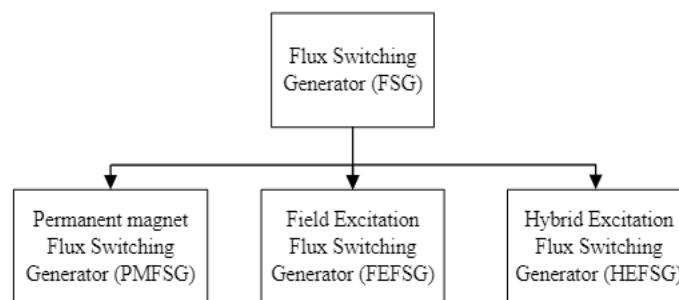

Fig. 2. Classification of FSG.

Additionally, hybrid excitation experiences significant position conflict and winding linking due to the complex arrangement of permanent magnets (PMs) and field windings on the stator side. Thus, the rotor space is not fully utilized that causes limits the rise of power density. Even though the hybrid excitation generator successfully addresses the issues of permanent magnet generator demagnetization, it will allow for customizable magnetic fields. Thus, it presents a new challenge in terms of low power density and efficiency when it comes to practical use [29]. However, Gu et al. have proposed an axial parallel hybrid generator where the magnetic fields of both sections connect due to the armature

response caused by the alternating armature windings [30]. According to this, by increasing the armature the magnetic field can be strengthened yet will increase the generator's weight. Besides, in particular circumstances such as maritime purposes, the air gap in the generator can be easily modified to suit the surrounding conditions [31]. By applying excitation currents with varying amplitudes and polarities, the hybrid excitation operating mode may be utilized to control the air gap and increase the range of electromagnetic torque. This allows the generator to adjust and obtain the optimum amount of power [32]. Continuous research and validation contributed to the development of numerous HE structures which finally brings to the optimization method which will not affect the size of the topologies.

According to the authors in [33], they have directed their attention toward intelligent optimization algorithms in the optimization of parameters due to their attainment of maximum efficiency in generators and diverse machine learning designs. When it comes to optimization, enhancing the mechanical component's performance can have a substantial impact on the overall design's effectiveness and efficiency [34]. Specifically, elevating the coefficient of the hybrid excitation designs leads to increased power generation [35]. Heng et al. found that collaborators attract low-cost generators by reducing their weight [36]. Therefore, the optimization approach aims to enhance the generator's output performance and reduce its weight. These optimization methods include Deterministic Optimisation Algorithms and Local Optimisation Methods which are fine-grained controls over parameter values that give the optimal performance of the generator [37], [38]. Thus, the selection of the optimization methods depends on the generator's specific requirements and designs that ensure efficient parameters. However, this optimization method does not have a proper sequence that can affect the optimum output performances of the generator.

Hence, this study investigates the impact of varying sequences involving rotor, armature coil, and field excitation coil structures on optimization through the utilization of the Local Optimisation Method (LOM). The configuration has a stator slot armature winding consisting of twelve slots and a rotor with ten poles. The repeated development of comparisons involving the diameters of each part, as well as the volume of NdFeB permanent magnets, has been observed. The generator underwent analysis at a maximum rotational speed of 600 revolutions per minute (rpm). The analysis of the hybrid excitation flux switching generator was performed using the 2D finite element analysis (FEA) method. The final section of this paper presents the findings and recommendations of the most suitable sequence that can be used during the optimization process.

2. DESIGN OPTIMIZATION PARAMETERS OF HEFSG

Specifically, the method used for the optimization process of the Hybrid Excitation Flux Switching Generator utilized the two-dimensional finite element method. This HEFSG configuration consists of five main parts: 12 stator slots, 10 rotor poles, permanent magnets, a field excitation coil, and an armature coil. The permanent magnets are made of rare-earth material, specifically neodymium magnets, NdFeB, with a density of 7550 kg/m³. The polarity of attraction in permanent magnets is mutually opposing. Because of the rotor's configuration, the mechanical rotation of the rotor causes an eventual change in the linkage of flux in certain rotor positions. Therefore, the initial design parameters of the HEFSG are shown in Table 1 and illustrated in Fig. 3. The initial design functions as an initial basis for optimization by utilizing a few sequences of each part.

Table 1. Initial design parameters of HEFSG.

Specifications	Parameters
Inner Rotor Diameter (mm)	32
Outer Rotor Diameter (mm)	184
Inner Stator Diameter (mm)	185
Outer Stator Diameter (mm)	284
Stack length (mm)	30
Air gap (mm)	1
Number of poles	10
Number of poles	12

The cross-sectional analysis of the hybrid excitation flux switching generator (HEFSG) topology indicates that the armature winding coils are positioned in a concentrated manner between segmented permanent magnets (PMs) and field excitation (FEs) with radial magnetization patterns. It also consists of a flux bridge, flux barrier, and magnetic field [7]. Other than that, the load profile of a generator may be characterized by its dependence on the rotational speed of the shaft and the distribution of shaft speeds. Therefore, the mechanical speed that applied to this generator is 600rpm.

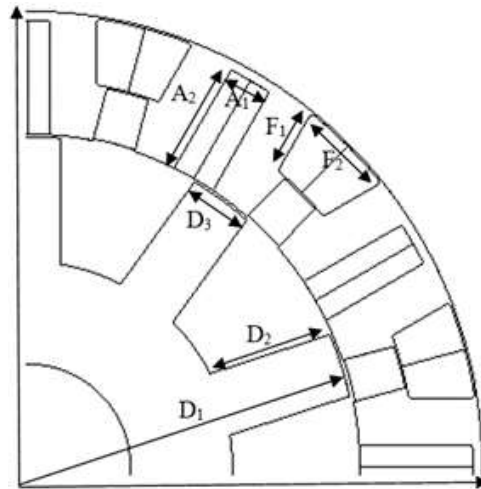

Fig. 3. Illustration of HEFSG.

Moreover, LOM is then used to optimize the parameters of the rotor parts followed by the armature coil and field excitation coil in various sequences. This is carried out to attain the maximum performance of the HEFSG as presented in Table 2. According to the data shown in the table, the sequences of each part are determined by the statistical probability of their constraints respectively. Next, the electromagnetic performance of the developed HEFSG is improved by employing the LOM. It will utilize several important performance metrics including flux linkage (Φ), flux linkage Harmonic (Φ_h), back electromotive force (V), cogging torque (T_{cog}), torque ripples (T_r), torque density (T_d), average power (P_{avg}), and power density (P_d) [39]. In general, the implementation of LOM involves a series of processes that follow a well-defined flow as depicted in Fig. 4. The optimization cycles of the parameters, including rotor radius, D_1 , rotor depth, D_2 , rotor width, D_3 , armature length A_1 , armature length A_2 , field excitation width F_1 , and field excitation length F_2 will be conducted based on the stated sequences. Subsequently, the optimization process will be iterated for all sequences pertaining to each generator part until it attains the optimal output performance with a scaling factor of 0.1 and maintains consistent settings in terms of speed and materials. However, to validate this research, this design's optimization technique will be compared with [40], in order to verify the sequence during the optimization process.

Table 2. Sequences constraints of HEFSG.

Specifications	Sequence
Rotor	1. $D_1 - D_2 - D_3$
	2. $D_1 - D_3 - D_2$
	3. $D_2 - D_3 - D_1$
	4. $D_2 - D_1 - D_3$
	5. $D_3 - D_2 - D_1$
	6. $D_3 - D_1 - D_2$
Armature coil	1. $A_1 - A_2$
	2. $A_2 - A_1$
Field excitation coil	1. $F_1 - F_2$
	2. $F_2 - F_1$

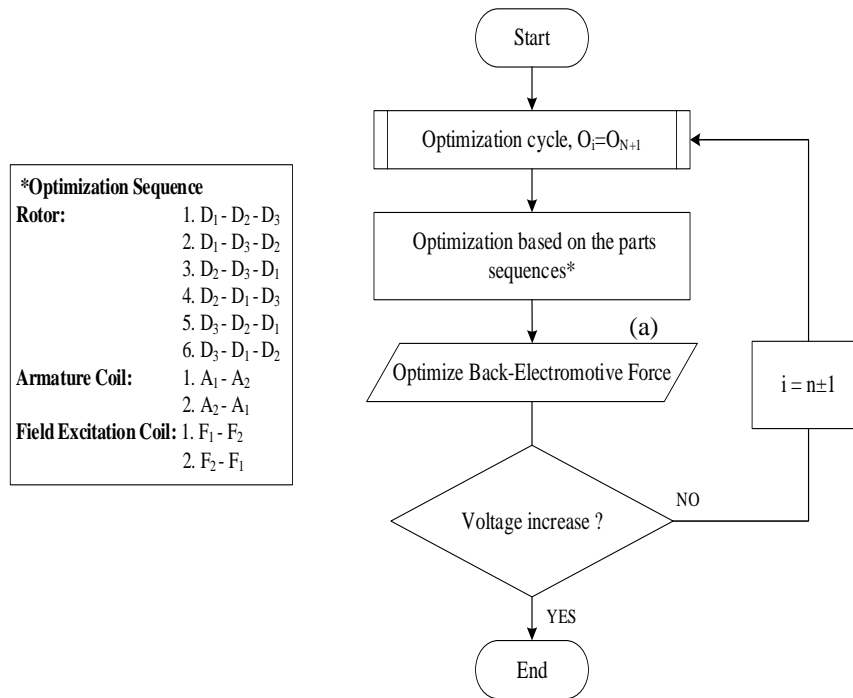

Fig. 4. Geometrical sequences optimization of HEFSG.

3. OPTIMIZATION RESULTS COMPARISON

The initial topology of the HEFSG was determined by utilizing a local optimization procedure with 2-dimensional Finite Element Analysis (FEA). Fig. 5 illustrates the coil flux linkage of the initial design HEFSG. According to the figure, it is evident that when subjected to identical armature currents and varying polarities. Moreover, the flux linkage exhibits symmetrical and sinusoidal characteristics and achieves 0.354Wb which can produce 377.66 V of back electromotive force (B-emf). Fig. 6(a) shows the initial topology of HEFSG and Fig. 6(b) indicates the optimized design of HEFSG. It is crucial to maximize the magnetic flux while incorporating the maximum number of conductors in series to enhance the induced voltage for each coil, considering the impact of the generator design on the induced voltage waveform.

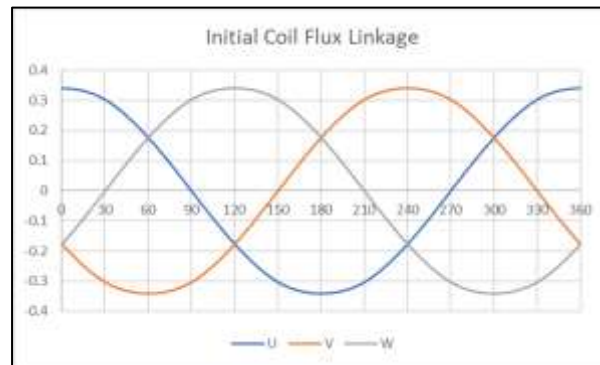

Fig. 5. Initial coil flux linkage of HEFSG.

Moreover, The flux distribution of the HEFSG is primarily determined by the excitation current. The pattern of flux under various excitation sources, specifically the PM source and the combination of PM and FEC, is illustrated in Fig. 7. The flux related to the armature windings is a result of the combined contributions of both the permanent magnet (PM) flux and the field-excited coil (FEC) flux. The analysis demonstrates that the manipulation of flux linkage can be effectively achieved through the process of field current exhibiting varying polarity. Therefore, the investigation of the flux strengthening and flux weakened capacity is extended to encompass a range of armature current densities and field excitation current densities which undergo a maximum value of $30A/mm^2$.

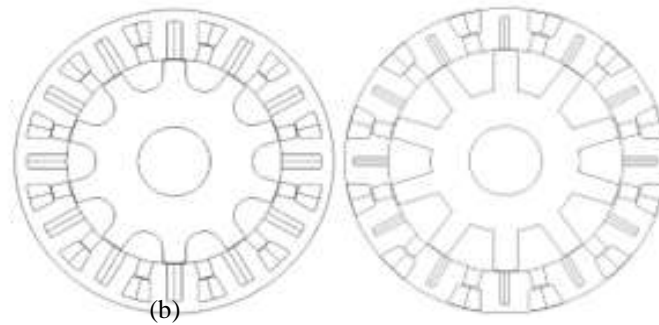

Fig. 6. (a) Initial HEFSG (b) Optimized HEFSG.

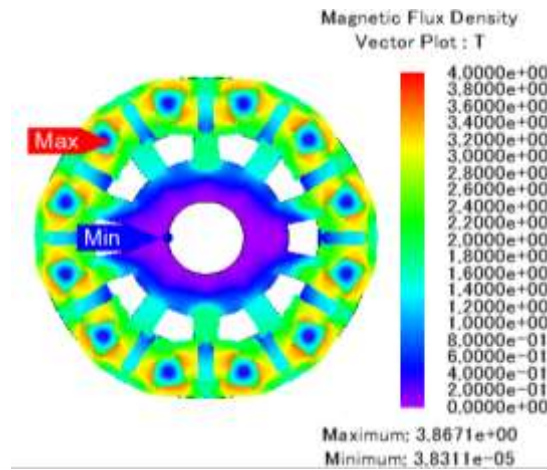
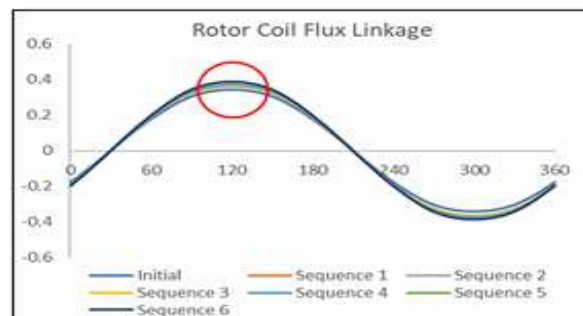

Fig. 7. Flux distribution of HEFSG.

3.1. Rotor Sequence Optimization

The dimension of a rotor may influence the stability and steadiness of the rotating arrangement. A longer rotor generally increases the stability of the generator by providing a larger moment of inertia, which resists changes in rotational speed. This can be important in applications where maintaining a stable speed is critical, such as in power generation or high-precision machinery [41]. Besides, the depth of a rotor can impact the efficiency and performance of rotating systems. In applications such as turbines, a longer rotor can provide more surface area for energy transfer, leading to improved efficiency.

However, it also increases frictional losses and may require additional support bearings, which can introduce iron or copper losses and reduce efficiency. The rotor has been optimized by using the Local Optimization Method within a 1mm discrepancy. Fig. 8 presents the recorded data pertaining to the optimization of the rotor's performances in terms of flux linkage, back-electromotive force, and cogging torque. Based on the presented data, it can be observed that there is a significant increase in the flux linkage between each coil, with values rising from 0.29Wb to 0.35Wb.



(a)

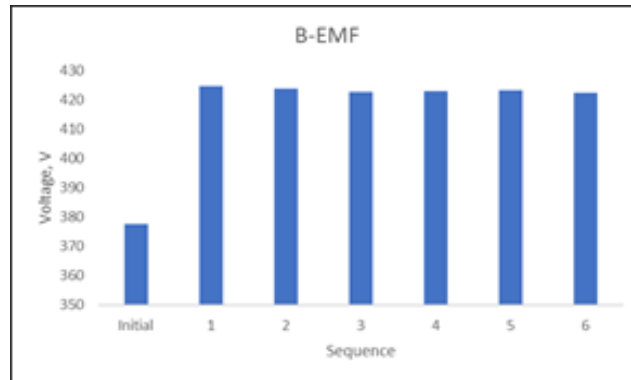

(b)

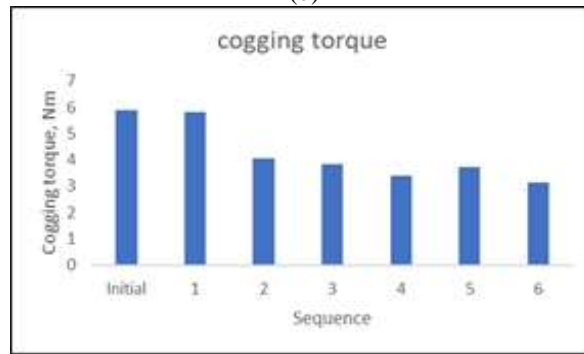

(c)

Fig. 8. Optimization results of the rotor on (a) Flux linkage (b) B-emf (c) Cogging torque.

The optimization yielded highly promising results, demonstrating significant enhancements in several elements of the rotor's structure. By employing comprehensive methodologies such as the Local Optimization Method, the design of the rotor was enhanced to optimize its stability and reduce undesirable losses. The adjustments made to the depth and length of the rotor were crucial in attaining these enhancements with six sequences. The rotor that was optimized demonstrated improved stability using a greater length, resulting in an increased moment of inertia. This enhancement increased the rotor's capacity to withstand variations in rotational velocity, guaranteeing a more uniform and dependable functioning. Based on the findings, it can be observed that the impact of optimization on sequence 1 indicates 424.79V of b-emf with 5.82Nm of cogging torque.

3.2. Armature Coil Sequence Optimization

Furthermore, the magnetizing coils which apart from magnetization control transients, allow for sequential flux optimization when not energized. This enables the transition of the magnetizing coils from DC magnetizing to AC armature. The relevant winding connection can be observed in Fig. 9. According to the figure, sequence 2 illustrates the high b-emf with a value of 474.48V compared to sequence 1 with 474.0674 respectively. In addition, the cogging torque value of both sequential shows a significant difference where sequence 1 with 16.52Nm and sequence 2 is 16.73Nm.

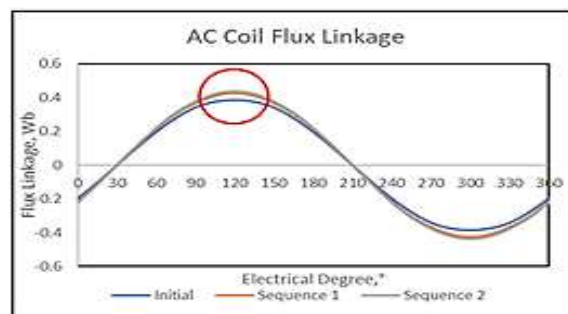

(a)

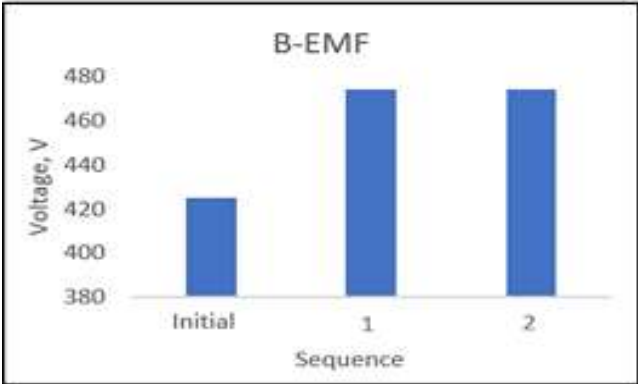

(b)

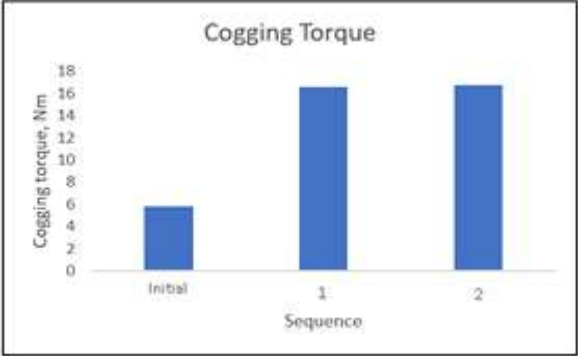

(c)

Fig. 9. Optimization results of armature coil on (a) Flux linkage (b) B-emf (c) Cogging torque.

3.3. Field Excitation Sequence Optimization

During the phase of excitation, the electricity flow is passed through the winding phase as shown in Figure 10(a), resulting in the magnetization of the core of the machine. The investigation of the influence of the field excitation coil dimension is conducted in this optimization step by modifying the parameters, F1 and F2. The optimization method involved determining the maximum and minimum values in order to prevent magnetic saturation and achieve a consistent distribution of the magnetic field.

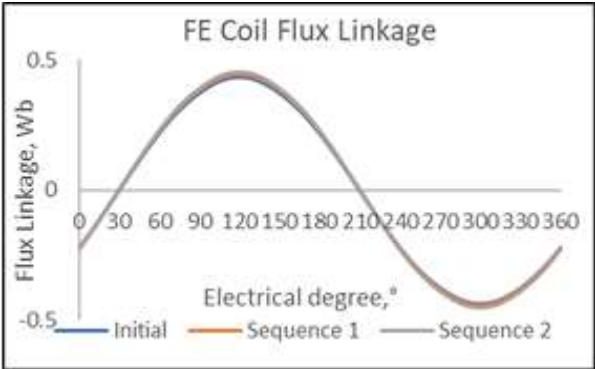

(a)

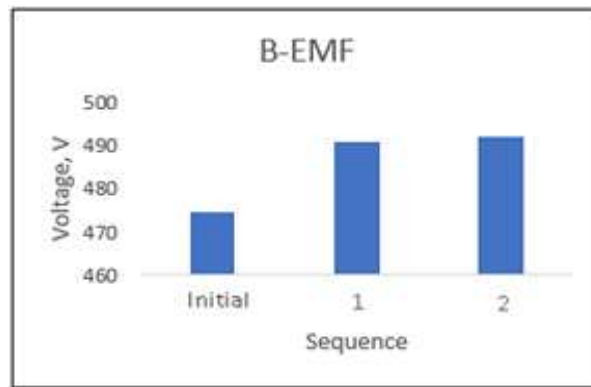

(b)

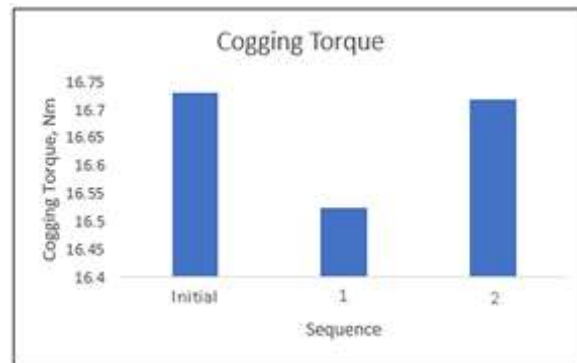

(c)

Fig. 10. Optimization results of Field excitation coil on (a) Flux linkage (b) B-emf (c) Cogging torque.

Throughout the electricity production part, the energy produced in the magnetic core from the preceding phase, mechanical power generated by the rotational motion of the rotor's shaft, is transmitted onto the load. This transmission facilitates the conversion of the back electromotive force (EMF) into electrical power. Consequently, following the optimization of this arrangement, it was able to attain an output of 491.93V, as depicted in Figure 10(b). The provided graphic presents a comparison between two sequences, revealing that sequence two has better results in comparison to sequence one. Furthermore, the determination and utilization of the generated voltage's fundamental value is a prevalent practice in the context of larger generators, aiming to attain optimal performance outcomes. Moreover, the comparison of cogging torque values between both sequences is shown in Figure 10(c). When compared with both sequences of the optimized configuration, it can be observed that the maximum cogging torque values slightly increased where the maximum peak-to-peak cogging torque value of sequence 1 is 16.523Nm while sequence 2 shows 16.718Nm after optimization, respectively.

4. CONCLUSION

In conclusion, this study outlines a few sequential structure optimizations of the Hybrid Excitation Flux Switching Generator using the Local Optimization Method (LOM). According to the results obtained, the output voltage shows a 28.75% increase. However, the cogging torque shows an increment after the optimization process from 5.87Nm to 16.718Nm. It can be concluded that the suitable sequence of rotor to use this method is sequence 1 which starts with the optimization of rotor radius, followed by rotor depth and rotor width to achieve better generator performance. The rotor underwent a thorough optimization process aimed at improving its performance and efficiency. Moreover, for the armature coil, the most suitable sequence that can be utilized during optimization is sequence 2 which starts with optimizing the armature coil length followed by width. Different from the field excitation coil part, the suitable sequential for optimizing the parts is by optimizing the width followed by their length. However, all these sequential of each part indicate a significant difference between others. In general, this research validates the optimization of the HEFSG to enhance or diminish the output performance of the generator. Additionally, it establishes that the control of flux is completely determined by the flux capability.

Data Availability. Data underlying the results presented in this paper are available from the corresponding author

upon reasonable request.

Funding. The research conducted in this study was financially supported by a Research Enhancement Graduate Grant (RE-GG Grant Q082) provided by Universiti Tun Hussein Onn Malaysia.

Conflicts of interest. The authors declare no conflict of interest.

Ethics. The authors declare that the present research work has fulfilled all relevant ethical guidelines required by COPE.



This article is licensed under a Creative Commons Attribution 4.0 International License.

©The Author(s) 2024

REFERENCES

- [1] S. Reddy Salkuti, “Energy Storage Technologies for Smart Grid: A Comprehensive Review,” *Majlesi Journal of Electrical Engineering*, vol. 14, no. 1, 2020.
- [2] F. S. Hafez *et al.*, “Energy Efficiency in Sustainable Buildings: A Systematic Review with Taxonomy, Challenges, Motivations, Methodological Aspects, Recommendations, and Pathways for Future Research,” *Energy Strategy Reviews*, vol. 45. Elsevier Ltd, Jan. 01, 2023.
- [3] A. Zygierewicz and Lucia. S. Sanz, “Renewable Energy Directive Revision of Directive (EU) 2018/2001,” 2018.
- [4] D. Gielen, F. Boshell, D. Saygin, M. D. Bazilian, N. Wagner, and R. Gorini, “The role of renewable energy in the global energy transformation,” *Energy Strategy Reviews*, vol. 24, pp. 38–50, Apr. 2019.
- [5] H. Gör and E. Kurt, “Preliminary studies of a new permanent magnet generator (PMG) with the axial and radial flux morphology,” *Int J Hydrogen Energy*, vol. 41, no. 17, pp. 7005–7018, 2016.
- [6] S. Djebbari, J. F. Charpentier, F. Sculler, and M. Benbouzid, “Design methodology of permanent magnet generators for fixed-pitch tidal turbines with overspeed power limitation strategy,” *Journal of Ocean Engineering and Science*, vol. 5, no. 1, pp. 73–83, 2020.
- [7] V. Dmitrievskii, V. Prakht, and V. Kazakbaev, “Design optimization of a permanent-magnet flux-switching generator for direct-drive wind turbines,” *Energies (Basel)*, vol. 12, no. 19, Sep. 2019.
- [8] Z. X. Fang, Y. Wang, J. X. Shen, and Z. W. Huang, “Design and Analysis of a Novel Flux-Switching Permanent Magnet Integrated-Starter-Generator,” 2008.
- [9] E. Limouchi, S. Abbas Taher, and B. Ganji, “Power and Frequency Control of Active Generator used for Smart Grid Applications,” *Majlesi Journal of Electrical Engineering*, vol. 14, no. 1, 2020.
- [10] S. Hamidizadeh, N. Alatawneh, R. R. Chromik, and D. A. Lowther, “Comparison of Different Demagnetization Models of Permanent Magnet in Machines for Electric Vehicle Application,” *IEEE Trans Magn*, vol. 52, no. 5, pp. 2–5, 2016.
- [11] S. Sjökvist, “Demagnetization Studies on Permanent Magnets Experiments,” *Dissertation*, p. 43, 2014.
- [12] J. Faiz and H. Nejadi-Koti, “Demagnetization Fault Indexes in Permanent Magnet Synchronous Motors-An Overview,” *IEEE Trans Magn*, vol. 52, no. 4, 2016.
- [13] J. Faiz, “Demagnetization Fault Indexes in Permanent Magnet Synchronous Motors — An Overview,” vol. 52, no. 4, 2016.
- [14] S. A. Mirnikjoo, K. Abbaszadeh, and S. E. Abdollahi, “Multiobjective Design Optimization of a Double-Sided Flux Switching Permanent Magnet Generator for Counter-Rotating Wind Turbine Applications,” *IEEE Transactions on Industrial Electronics*, vol. 68, no. 8, pp. 6640–6649, Aug. 2021.
- [15] J. Schaarup and T. Krogh, “Guidelines for design of wind,” *Proc. Ris- Vinddag*, pp. 5–9, 2001.
- [16] H. Ali, E. Sulaiman, and R. Aziz, “Review of Double Stator Flux switching machines with various arrangements of excitation sources,” *Alexandria Engineering Journal*, vol. 60, no. 5, pp. 4393–4410, 2021.
- [17] Y. Zhao, H. Wang, and L. Xiao, “Investigation of fault-tolerant capability of five-phase doubly salient electromagnetic generator,” *IET Electr Power Appl*, vol. 9, no. 1, pp. 80–93, Jan. 2015.
- [18] A. Ghaheri, E. Afjei, and H. Torkaman, “Design optimization of a novel linear transverse flux switching permanent magnet generator for direct drive wave energy conversion,” *Renew Energy*, vol. 198, pp. 851–860, Oct. 2022.
- [19] V. Prakht, V. Dmitrievskii, V. Kazakbaev, and M. N. Ibrahim, “Comparison between rare-earth and ferrite permanent magnet flux-switching generators for gearless wind turbines,” *Energy Reports*, vol. 6, pp. 1365–1369, Dec. 2020.
- [20] J. Li *et al.*, “Generating performance of a tubular permanent magnet linear generator for application on free-piston engine generator prototype with wide-ranging operating parameters,” *Energy*, vol. 278, Sep. 2023.
- [21] W. Ullah, A. Selema, and F. Khan, “Design and comparative analysis of dual rotor wound field excited flux switching generator for household DC microgrid system with rooftop wind turbine,” *Appl Energy*, vol. 357, Mar. 2024.
- [22] H. Geng *et al.*, “Magnetic field analysis and performance optimization of hybrid excitation generators for vehicles,” *Sustainable Energy Technologies and Assessments*, vol. 52, Aug. 2022.
- [23] Z. Wang, S. Liu, Z. Yang, and S. Dong, “Perspective on Development of Piezoelectric Micro-Power Generators,” *Nanoenergy Advances*, vol. 3, no. 2, pp. 73–100, Apr. 2023.

- [24] Z. Li *et al.*, “Performance comparison of electromagnetic generators based on different circular magnet arrangements,” *Energy*, vol. 258, Nov. 2022.
- [25] S. Zhu, C. Liu, K. Wang, Y. Hu, and Y. Ning, “Theoretical and experimental analyses of a hybrid excitation synchronous generator with integrated brushless excitation,” *IET Electr Power Appl*, vol. 10, no. 4, pp. 258–267, Apr. 2016.
- [26] K. Chen, Y. Wang, and Y. Xia, “A High Power Density Partitioned Stator Compound Modulation Hybrid Excitation Generator for Special Vehicles,” Institute of Electrical and Electronics Engineers (IEEE), Dec. 2023, pp. 1032–1037.
- [27] A. G. Durakova, A. L. Bogoeva, and A. P. Krasteva, “Study of a linear generator with permanent magnets converting sea wave energy into electricity Study of a linear generator with permanent magnets c onverting sea wave energy into electricity,” 2020.
- [28] L. Shi, J. An, and W. Zhang, “Topology Comparison Study of Five-Phase Wound-Field Doubly Salient Fault Tolerant Generators,” 2019.
- [29] H. Wang, K. Wang, Y. D. Guo, J. Li, and F. Li, “Improvement of Output Power for AC Hybrid Excitation Brushless Generator with Novel Consequent-pole Rotor,” Institute of Electrical and Electronics Engineers (IEEE), Dec. 2023, pp. 5239–5244.
- [30] X. Gu, Z. Zhang, L. Sun, and L. Yu, “Magnetic Field Enhancement Characteristic of an Axially Parallel Hybrid Excitation DC Generator,” *IEEE Trans Magn*, vol. 57, no. 2, Feb. 2021.
- [31] Y. Li, L. Huang, M. Chen, P. Tan, and M. Hu, “A Hybrid Excitation Axial Flux Permanent Magnet Generator for Direct Drive Wave Energy Conversion,” in *Digests of the Intermag Conference*, Institute of Electrical and Electronics Engineers Inc., 2021.
- [32] S. B. Mallampati and H. Seetha, “A Review on Recent Approaches of Machine Learning, Deep Learning, and Explainable Artificial Intelligence in Intrusion Detection Systems,” *Majlesi Journal of Electrical Engineering*, vol. 17, no. 1, pp. 29–54, Mar. 2023.
- [33] W. Shafqat, K. T. Lee, and D. H. Kim, “A Comprehensive Predictive Learning Framework for Optimal Scheduling and Control of Smart Home Appliances Based on User and Appliance Classification,” *Sensors*, vol. 23, no. 1, Jan. 2023.
- [34] B. Thamaraikannan and V. Thirunavukkarasu, “Design optimization of mechanical components using an enhanced teaching-learning based optimization algorithm with differential operator,” *Math Probl Eng*, vol. 2014, 2014.
- [35] S. A. Mirnikjoo, K. Abbaszadeh, and S. E. Abdollahi, “Multiobjective Design Optimization of a Double-Sided Flux Switching Permanent Magnet Generator for Counter-Rotating Wind Turbine Applications,” *IEEE Transactions on Industrial Electronics*, vol. 68, no. 8, pp. 6640–6649, Aug. 2021.
- [36] T. Yee Heng, T. Jian Ding, C. Choe Wei Chang, T. Jian Ping, H. Choon Yian, and M. Dahari, “Permanent Magnet Synchronous Generator design optimization for wind energy conversion system: A review,” *Energy Reports*, vol. 8, pp. 277–282, Dec. 2022.
- [37] Y. Zhang, S. Wang, and G. Ji, “A Comprehensive Survey on Particle Swarm Optimization Algorithm and Its Applications,” *Mathematical Problems in Engineering*, vol. 2015, Hindawi Limited, 2015.
- [38] P. Linardatos, V. Papastefanopoulos, and S. Kotsiantis, “Explainable ai: A review of machine learning interpretability methods,” *Entropy*, vol. 23, no. 1, MDPI AG, pp. 1–45, Jan. 01, 2021.
- [39] M. A. Khanabadi, I. Dehghani, and S. Shojaeian, “Optimal Power Generation from Bagasse in a Sugarcane Plant using PSO Algorithm Compared to SQP Algorithm,” *Majlesi Journal of Electrical Engineering*, vol. 14, no. 2, 2020.
- [40] E. Sulaiman, “Hybrid Excitation Flux Switching Motor,” Ph.D dissertation, Universiti Tun Hussein Onn Malaysia, Malaysia, 2012.
- [41] O. Ouledali, A. Meroufel, P. Wira, and S. Bentouba, “Torque and Stator Flux Ripples Minimization for Direct Torque Control of PMSM by using Space Vector Modulation,” *Majlesi Journal of Electrical Engineering*, vol. 12, no. 3, 2018.